

Airport Business Park Station

Construction Traffic Management Plan

Document no. SMWSASSM-PLD-ABP-TF-PLN-000001

ABP CTMP

Date: 14/07/2023

Version Rev A

Internal Reference: SMWSASSM-PLD-ABP-TF-PLN-000001

Version Control

Version	Author	Date	Comments	Approved by
Rev A	Wendy Zheng	09/06/2023	First Issue	Richard Graham
Rev B	Wendy Zheng	14/07/2023	Second Issue	Richard Graham



Contents

1	Introduction	9
2	Executive Summary	22
3	Project Details	23
3.1	Proposed Works.....	23
3.2	Site Location	24
3.3	Timing of Works	25
3.4	Site Related Data	25
3.4.1	Road Details.....	25
3.4.2	Crash History.....	26
3.4.3	Vulnerable Road Users	27
4	Works Proposed.....	29
4.1	Access Staging.....	29
4.2	Station Construction	30
4.3	Rail Construction	30
4.4	Temporary Concrete Batching Plant	31
4.5	Site Access (Access Portion 01)	32
4.6	Construction Hours.....	32
4.7	Construction Vehicle Movements	33
4.7.1	Truck Vehicle Volume	33
4.7.2	Truck Routes	34
4.8	Temporary Traffic Management Method	35
4.8.1	Access Portion 01	35
4.8.2	Access Portion 02 and 03	37

4.9	Risk Assessment.....	38
5	Traffic Impact Management.....	39
5.1	Vehicle Impact Management.....	39
5.2	Pedestrian / Cyclist Impact Management.....	40
5.3	Public Transport Impact Management.....	40
5.4	Property and Utility Access Impact Management.....	40
5.5	Cumulative Impacts.....	40
5.6	Authorised Traffic Controller.....	41
6	Parking Management.....	42
6.1	Access Portion 01.....	42
6.2	Access Portion 02 and 03.....	43
7	Agency Permits.....	45
7.1	Council Permits.....	45
7.2	Local Traffic Committee.....	45
7.3	Road Dilapidation Report.....	45
7.4	OSOM Permits.....	45
7.5	Speed Zone Authorisation Permits.....	45
7.6	Western Sydney Airport Building Approval Number.....	45
8	Community Notification.....	46
8.1	Site Contact.....	46
8.2	Propose Communications.....	46
8.3	Travelling Public.....	47
8.4	Variable Message Signs.....	47

8.5	Stakeholders	47
9	Monitoring and Review	48
9.1	Road Safety Audit	48
9.2	Monitoring Program.....	48
9.3	Work Site Inspections, Recording and Reporting	48
9.4	Environmental Maintenance	49
Appendix A	Swept Path Assessment	50
Appendix B	Risk Assessment	51
Appendix C	Stakeholder Comments	52
Appendix D	Road Safety Audit	53
Appendix E	Drivers Code of Conduct.....	54

Table of figures

FIGURE 1: SITE LOCATION	24
FIGURE 2: CRASH MAP	26
FIGURE 4: ABP ACCESS STAGING PLAN	29
FIGURE 3: ABP STATION ARCHITECTURAL ELEVATIONS (PRELIMINARY).....	30
FIGURE 10: ABP TEMP CONCRETE BATCHING PLANT LOCATION	31
FIGURE 5: ABP SITE ACCESS.....	32
FIGURE 6: PROJECTED ABP HV NUMBERS.....	33
FIGURE 7: CONSTRUCTION VEHICLE ACCESS ROUTE	35
FIGURE 8: 19M AV ACCESS THROUGH LOCATION 1A	36
FIGURE 9: 19M AV ACCESS THROUGH LOCATION 1F.....	37

FIGURE 11: PROPOSED ACCESS PORTION 01 PARKING PLAN.....	43
FIGURE 12: ACCESS PORTION 02 CARPARKING.....	44

Table of tables

TABLE 1: DOCUMENT CHANGES / UPDATES	10
TABLE 2: TIMING OF WORKS.....	25
TABLE 3: LOCAL ROAD NETWORK	25
TABLE 4: CRASH HISTORY	27
TABLE 5: PUBLIC AND ACTIVE TRANSPORT	27
TABLE 6: CONSTRUCTION HOURS.....	33
TABLE 7: PROJECTED VEHICLE NUMBERS.....	39
TABLE 8: PROPOSED COMMUNICATIONS	46

Glossary

Acronym	Description
AGRD	Austrroads Guide to Road Design
AGTM	Austrroads Guide to Traffic Management
AGRS	Austrroads Guide to Road Safety
Ancillary facility	A temporary facility for construction of the CSSI including an office and amenities compound, construction compound, material crushing and screen plant, materials storage compound, maintenance workshop, testing laboratory and material stockpile area and parking facilities
CEMP	Construction Environmental Management plan
CJP	Customer Journey Planning (TfNSW)
CNVS	Construction Noise and Vibration Standard
CPTED	Crime Prevention through Environmental Design
CTMF	Construction Traffic Management Framework
DPE	Department of Planning and Environment (formerly Department of Planning, Industry and Environment)
EIS	Environmental Impact statement
EMF	Environmental Management Framework
EMP	Environmental Management Plan
EMS	Environmental Management System
EPA	Environmental Protection Authority
EP&A Act	Environmental Planning and Assessment Act 1979
EP&A Regulation	Environmental Planning and Assessment Regulation 2000
Evening	The period from 6pm to 10pm
Feasible	Means what is possible and practical in the circumstances
Night	The period from 10pm to 7am on Monday to Saturday, and 10pm to 8am on Sundays and Public Holidays.
NSW RFS	New South Wales Rural Fire Service
OEMP	Operational Environmental Management Plan

Acronym	Description
DCP	Development Control Plan
DoS	Degree of Saturation
LEP	Local Environmental Plan
LGA	Local Government Area
LoS	Level of Service
NHVR	National Heavy Vehicle Regulator
RMS Guide	Transport for NSW (formerly Roads and Traffic Authority), Guide to Traffic Generating Developments, 2002
TDT 2013/04a	TfNSW Technical Direction, Guide to Traffic Generating Developments – Updated traffic surveys, August 2013
TfNSW	Transport for New South Wales
veh/hr	Vehicle movements per hour (1 vehicle in & out = 2 movements)

1 Introduction

This site-specific Construction Traffic Management Plan (CTMP) was created as per the Sydney Metro Construction Traffic Management Framework (CTMF), the general specification management of the Project, the Western Sydney Airport Construction Environmental Management Plans and Overarching Construction Management Plan - Sydney Metro Western Sydney Airport.

The scope of this CTMP is to detail the traffic and transport impacts and management measures associated with the traffic management required to facilitate the construction of the Airport Business Park Station (ABP). The entirety of ABP construction works will take place within Western Sydney Airport (WSA) land where WSA CEMPs apply.

Access to this site will be handed to SSTOM (being Parklife Metro) in three stages:

- Access Portion 01: August 2023 (station construction)
- Access Portion 02: May 2024 (rail construction, at grade Linewide)
- Access Portion 03: July 2024 (rail construction, tunnel Linewide)

ABP is the southern station where Linewide will transition from at grade to tunnel through the station building.

As there is a projected ten months between Access Portion 01 and Access Portion 02 handover with significant construction progress forecasted in between, this CTMP will be updated with details for Access Portion 02 and 03 traffic management prior to handover.

This CTMP and the documents referenced in the CTMP have been prepared in accordance with the relevant standards and guidelines listed in the SSTOM Overarching Construction Traffic Management Plan (SMWSASSM-PLD-1NL-PC-PLN-000071).

This plan has been prepared to meet the following requirement including SSI 10051 Planning Approval Condition E103 and will be submitted to the Planning Secretary of the NSW Department of Planning and Environment for information.

- Environmental Impact Statement (EIS) of Sydney Metro Western Sydney Airport – Technical Paper 1 - Transport Mitigation Measures
- EIS Construction Traffic Management Framework
- Conditions of Approval (CoA) for the State Significant Infrastructure (SSI 10051)
- SMWSA Traffic and Access CEMP

This plan has been prepared to also meet the requirements outlined in the WSA plans:

- WSA Construction Environmental Management Plans
- WSA Airport Plan
- WSA Cumulative Impacts Plan

This report has been prepared by the traffic manager who holds a SafeWork NSW Work Health & Safety Traffic Control Work card, accredited for the 'Prepare a Work Zone Traffic Management Plan'. Details of the accredited personnel is provided below:

- Wendy Zheng Ticket No. TCT1015144

This report has been reviewed by personnel who holds a SafeWork NSW Work Health & Safety Traffic Control Work card, accredited for the 'Prepare a Work Zone Traffic Management Plan'. Details of the accredited personnel is provided below:

- Dora Choi Ticket No. TCT0021456

This Construction Traffic Management Plan has been prepared to meet the requirements outlined in Appendix A and Appendix E, Section E.2 of the Transport for NSW Traffic Control at Work Sites Technical Manual (Issue No. 6.1, 2022).

TABLE 1: DOCUMENT CHANGES / UPDATES

Date	Section	Original Text	Changes Made (new / additional text in green)
12/07/2023	Appendix E	New appendix	Driver's Code of Conduct for ABP
12/07/2023	4	4.1 Station Construction 4.2 Rail Construction 4.3 Access Staging 4.4 Site Access (Access Portion 01) 4.5 Construction Hours 4.6 Construction Vehicle Movements 4.7 Temporary Traffic Management Method 4.8 Temporary Concrete Batching Plant	4.1 Access Staging 4.2 Station Construction 4.3 Rail Construction 4.4 Temporary Concrete Batching Plant 4.5 Site Access 4.6 Construction Hours 4.7 Construction Vehicle Movements 4.8 Temporary Traffic Management Method
12/07/2023	5.2	There is a footpath on either sides of Badgerys Creek Road starting south of the Elizabeth Dr intersection and stopping north of the Pitt Street intersection. PLM D&C will be sharing the existing accesses to WSA site off Badgerys Creek Road and will be adhering to all existing pedestrian / cyclist impact management measures. Note that all delivery drivers will be briefed to be aware of pedestrians and / or cyclists at all times.	There is a shared path on either side of Badgerys Creek Road starting south of the Elizabeth Dr intersection and stopping north of the Pitt Street intersection separated from the traffic lane by a wide shoulder . PLM D&C will be sharing the existing accesses to WSA site off Badgerys Creek Road and will be adhering to all existing pedestrian / cyclist impact management measures. Note that all drivers accessing the site will be licenced and briefed via the induction and daily toolbox talks to be aware of pedestrians and / or cyclists at all times. This is further reinforced in the Drivers' Code of Conduct (see Appendix E).
12/07/2023	7.2	New section – Local Traffic Committee	No works proposed in this CTMP will trigger a Local Traffic Committee referral.

12/07/2023	7.6	New section – Western Sydney Airport Building Approval Number	This CTMP will be submitted as part of PLM’s first Western Sydney Airport Building Approval Number (SSTOM BAN 01) submission.
12/07/2023	5.5	New text	Coordination with Western Sydney Airport and Transport for NSW would be undertaken through the TTLG to manage potential cumulative construction traffic impacts with M12 Motorway and Elizabeth Drive.
12/07/2023	4	The construction at ABP is broadly separated into two packages: <ul style="list-style-type: none"> • Station Construction (Access Portion 01) • Rail Construction 	The construction at ABP is broadly separated into two packages: <ul style="list-style-type: none"> • Station Construction (taking place within Access Portion 01) • Rail Construction (taking place within Access Portion 02 and 03)
12/07/2023	4.3	Rail construction is expected to start in October 2024 following SBT handover so that SSTOM is given access to the tunnel. This CTMP will be updated prior to rail construction package commencement.	Rail construction is expected to start in October 2024 following SBT and SCWA handover of Access Portions 02 and 03 so that SSTOM is given access to Linewide (tunnel and at grade). This CTMP will be updated prior to rail construction package commencement.
12/07/2023	1	This site-specific Construction Traffic Management Plan (CTMP) was created as per the Sydney Metro Construction Traffic Management Framework (CTMF), the general specification management of the Project and Overarching Construction Management Plan - Sydney Metro Western Sydney Airport. Access to this site will be handed to SSTOM (being Parklife Metro) in three stages:	This site-specific Construction Traffic Management Plan (CTMP) was created as per the Sydney Metro Construction Traffic Management Framework (CTMF), the general specification management of the Project, the Western Sydney Airport Construction Environmental Management Plans and Overarching Construction Management Plan - Sydney Metro Western Sydney Airport.

- Access Portion 01: August 2023 (refer to Section 4.3 for details)
- Access Portion 02: May 2024
- Access Portion 03: July 2024

As there is a projected ten months between Access Portion 01 and Access Portion 02 handover with significant construction progress forecasted in between, this CTMP will be updated with details for Access Portion 02 and 03 traffic management in early 2024.

This plan has been prepared to meet the following requirement including SSI 10051 Planning Approval Condition E103 and will be submitted to the Planning Secretary of the NSW Department of Planning and Environment for information.

- Environmental Impact Statement (EIS) of Sydney Metro Western Sydney Airport – Technical Paper 1 - Transport Mitigation Measures
- EIS Construction Traffic Management Framework
- Conditions of Approval (CoA) for the State Significant Infrastructure (SSI 10051)

Access to this site will be handed to SSTOM (being Parklife Metro) in three stages:

- Access Portion 01: August 2023 (station construction)
- Access Portion 02: May 2024 (rail construction, at grade Linewide)
- Access Portion 03: July 2024 (rail construction, tunnel Linewide)

ABP is the southern station where Linewide will transition from at grade to tunnel through the station building.

As there is a projected ten months between Access Portion 01 and Access Portion 02 handover with significant construction progress forecasted in between, this CTMP will be updated with details for Access Portion 02 and 03 traffic management prior to handover.

This plan has been prepared to meet the following requirement including SSI 10051 Planning Approval Condition E103 and will be submitted to the Planning Secretary of the NSW Department of Planning and Environment for information.

- Environmental Impact Statement (EIS) of Sydney Metro Western Sydney Airport – Technical Paper 1 - Transport Mitigation Measures
- EIS Construction Traffic Management Framework
- Conditions of Approval (CoA) for the State Significant Infrastructure (SSI 10051)
- SMWSA Traffic and Access CEMP

New text

This plan has been prepared to also meet the requirements outlined in the WSA plans:

- WSA Construction Environmental Management Plans
- WSA Airport Plan
- WSA Cumulative Impacts Plan

12/07/2023	4.7.2	<p>It is proposed that all construction vehicles would enter and exit the Site via the routes shown in Figure 7. The routes shown are to be utilised by all construction vehicles travelling to and from the site and represents the shortest route available from / to a State Road – hence minimising the impacts of the construction process. A copy of the approved routes will be distributed by PLM D&C to all drivers before their arrival to Site.</p> <p>The largest truck required for ABP construction will be 25m long Articulated Vehicles (25m AV) so an over-size over mass (OSOM) permit will be required for heavy vehicle access to site through Badgerys Creek Road. PLM D&C will obtain an OSOM permit from the National Heavy Vehicle Register (NHVR).</p>	<p>It is proposed that all construction vehicles would enter and exit the Site via the routes shown in Figure 7. The routes shown will be utilised by all construction vehicles travelling to and from the site and represents the shortest route available from / to a State Road – hence minimising the impacts of the construction process. A copy of the approved haul routes (OCTMP Appendix A and the site specific access route diagram) will be distributed by PLM D&C to all drivers as part of their site induction and reinforced in the Drivers' Code of Conduct.</p> <p>The largest truck required for ABP construction will be 19m long Articulated Vehicles (19m AV) so an over-size over mass (OSOM) permit will not be required for heavy vehicle access to site through Badgerys Creek Road. If required, PLM D&C will obtain an OSOM permit from the National Heavy Vehicle Register (NHVR).</p>
12/07/2023	4.4	<p>The WSA construction team will be decommissioning their on-site temporary concrete batching plant as it is within the airport footprint and the supplier will be relocating the temporary concrete batching plant to within ABP Access Portion 01 (location per Figure 10).</p>	<p>The WSA Terminal Contractor will be decommissioning their on-site temporary concrete batching plant as it is within the airport footprint and the supplier will be relocating the temporary concrete batching plant to within ABP Access Portion 01 (location per Figure 5). This batching plant is projected to be commissioned in April 2024.</p>

		<p>This temporary concrete batching plant will be supplying the construction works for ABP, Airport Terminal Station (ATL) and SSTOM Linewide (rail construction package) within the WSA site.</p> <p>Figure 5</p>	<p>This temporary concrete batching plant will be supplying the construction works for ABP, Airport Terminal Station (ATL) and SSTOM Linewide (rail construction package) within the WSA site and Aerotropolis (AEC) Station off-airport.</p> <p>Figure 5 updated</p>
12/07/2023	Appendix B, Risk Assessment Table Ref 3	<p>One-way manoeuvring around the site limits any interaction for oncoming vehicles to the access only, coupled with low speeds throughout the site.</p>	<p>One-way manoeuvring around the site limits any interaction for oncoming vehicles to the access only, coupled with low speeds throughout the site. In locations where one-way manoeuvring is not available, all drivers will radio on ahead before entering the two-way haul road section.</p>
12/07/2023	3.4.2	Figure 2	Figure 2 updated for clarity and legend
12/07/2023	3.4.3	<p>Table 5, The Northern Road, Pedestrian and Cycling</p> <p>Table 5, Badgerys Creek Road, Public Transport</p> <p>Table 5, Elizabeth Drive, Public Transport</p>	<p>No consistent footpath provision.</p> <p>Some intermittent footpaths on both sides of the road.</p> <p>No consistent cycleway provision off road.</p> <p>Some intermittent shared path on both sides of the road.</p> <p>Yes – bus routes 801 (last stop north of Gardiners Road), 1014, 2017, 2053 (first stop south of Longleys Road)</p> <p>Bus stops along roadway at Longleys Road and Gardiners Road only.</p> <p>Yes – bus routes 801 (west of Badgerys Creek Road only), 4147, 4510, 9057, 9615, 9616</p> <p>Bus stops along roadway</p>
12/07/2023	5.3	There is no public transport on Badgerys Creek Road.	

However, all delivery drivers will be briefed that buses are always given priority along the haul route.

12/07/2023	5.5	<p>PLM D&C traffic management will ensure the vehicle generation numbers (heavy and light) will be within the numbers identified in the EIS.</p> <p>Additionally, PLM D&C traffic management is an active participant in the TTLG, TCG and the TCWG meetings ensuring ongoing monitoring and discussion will occur over the life of the project.</p>	<p>PLM D&C traffic management will ensure the vehicle generation numbers (heavy and light) will be within the numbers identified in the EIS. All vehicular access to the ABP site will be registered a week in advance on the PLM logistics software to apply for a loading slot and a time or a parking space. The site superintendent will manage the applications to ensure vehicle generation numbers stay within the identified limits in the EIS. The same software will retain the vehicle data per SSI condition E108.</p> <p>PLM D&C traffic management is an active participant in the TTLG, TCG and the TCWG meetings ensuring ongoing monitoring and discussion will occur over the life of the project. Coordination with Western Sydney Airport and Transport for NSW would be undertaken through the TTLG and to manage potential cumulative construction traffic impacts with M12 Motorway and Elizabeth Drive.</p>
12/07/2023	4.5	<p>Figure 6</p> <p>Site access for all vehicles will be off Badgerys Creek Road through either Location 1A (roundabout at intersection with Pitt Street) or Location 1F (left in / left out only access road north of Pitt Street). Note that before Access Portion 02 handover PLM and their subcontractors will minimise the use of Location 1A as much as possible to mitigate the cumulative traffic impacts on it.</p>	<p>Figure 6 updated for clarity</p> <p>Site access for all SMWSA vehicles into WSA land will be off Badgerys Creek Road through either Location 1A (roundabout at intersection with Pitt Street) or Location 1F (left in / left out only access road north of Pitt Street). Note that before Access Portion 02 handover PLM and their subcontractors will minimise the use of Location 1A as much as possible to mitigate the</p>

cumulative traffic impacts on it. Prior to handover of Access Portion 02, access to ABP site for vehicles is significantly easier through Location 1F instead of Location 1A. Additionally, prioritization of Location 1F access this will be reinforced through site inductions, toolbox talks and the Driver's Code of Conduct.

Access to Access Portion 01 AND 03 for both SSTOM and SCAW will be off WSA LAR 08 with right in / left out from the north (Location 1F) prioritised.

SBT access to Access Portion 02 will be through Location 1A only and accessing the site off LAR09. SBT access to Access Portion 02 is entirely independent of Access Portion 01/03.

Following handover of Access Portion 02, SSTOM access for the Linewide tunnel works will be through the existing SBT access. Similarly following Access Portion 03 from SCAW, SSTOM will use the LAR09 SBT access shown on Figure 6 for Linewide at grade construction.

12/07/2023	4.6	Construction hours have been outlined below per Condition E38:	Construction hours have been outlined below per WSA00-WSA-00000-CN-PLN-000001 Construction Plan Rev 5 Section 3.3.2:
		It is anticipated that construction works may be conducted outside of the hours outlined above. Should out of work hours be required, per Conditions E41 and E42, PLM D&C will lodge an application with DPE to seek approval for these works.	It is not anticipated that construction works will be conducted outside of the hours outlined above. Should out of work hours be required, per Section 10.2 of WSA00-WSA-00400-EN-PLN-000002_NV CEMP (Rev 4), PLM will submit WSA00-WSA-00400-EN-FRM-000005 to the WSA Environment Team for review and approval by

the WSA Environment Manager
(or nominated delegate).

12/07/2023	4.7.1	Figure 7	Figure 7 updated for more defined construction HV numbers and concrete batching plant numbers.
		The anticipated heavy vehicle volume peak will start following complete Site handover in July 2024 and drops off following completion of station finishing works in August 2025.	The anticipated heavy vehicle volume peak will start in January 2024 and drops off following completion of station finishing works in April 2025 .
12/07/2023	4.8.1	Figure 9	Figure 8 updated for 19m AV
		Swept path assessments in Figure 8 show that the largest size heavy vehicle can access the site simultaneously without impacting Badgerys Creek Road at Location 1A.	Swept path assessments in Figure 8 show that the largest size heavy vehicle (19m AV) can access the site simultaneously without impacting Badgerys Creek Road at Location 1A.
		Similarly, 25m AV access to the access road from Badgerys Creek Road through Location 1F will not impact the existing operations of either roads per swept paths show in Figure 9.	Similarly, 19m AV access to the access road from Badgerys Creek Road through Location 1F will not impact the existing operations of either roads per swept paths show in Figure 9.
		Figure 10	Figure 9 updated for 19m AV
12/07/2023	4.7.2	The routes shown are to be utilised by all construction vehicles travelling to and from the site and represents the shortest route available from / to a State Road – hence minimising the impacts of the construction process. A copy of the approved routes will be distributed by PLM D&C to all drivers before their arrival to Site.	The routes shown are compliant with the EIS haul road routes and are to be utilised by all construction vehicles travelling to and from the site and represents the shortest route available from / to a State Road – hence minimising the impacts of the construction process. A copy of the approved routes will be distributed by PLM D&C to all drivers before their arrival to Site.
		The largest truck required for ABP construction will be 25m long Articulated Vehicles (25m AV) so an over-size over mass (OSOM) permit will be required for heavy vehicle access to site through	The largest truck required for ABP construction will be 19m long Articulated Vehicles (19m AV) so an over-size over mass (OSOM) permit will not be required for

Badgerys Creek Road. PLM D&C will obtain an OSOM permit from the National Heavy Vehicle Register (NHVR).

heavy vehicle access to site through Badgerys Creek Road. In the case that an OSOM permit is required, PLM D&C will obtain it from the National Heavy Vehicle Register (NHVR).

There is no pedestrian or cyclist path available along the route from either Elizabeth Drive or The Northern Road to Site. However if any access to existing properties is affected by construction vehicle access to site, traffic controllers or appropriate traffic management would be available on the accesses to direct existing property users while guiding construction vehicles.

There is a shared path on either side of Badgerys Creek Road starting south of the Elizabeth Dr intersection and stopping north of the Pitt Street intersection separated from the traffic lane by a wide shoulder. There are also bus stops along Badgerys Creek Road. PLM will be sharing the existing accesses to WSA site off Badgerys Creek Road and will be adhering to all existing pedestrian / cyclist / public transport impact management measures.

If any access to existing properties is affected by construction vehicle access to site, traffic controllers or appropriate traffic management would be available on the accesses to direct existing property users while guiding construction vehicles.

12/07/2023	5.3	<p>There is no public transport on Badgerys Creek Road.</p> <p>However, all delivery drivers will be briefed that buses are always given priority along the haul route.</p>	<p>There are four bus routes on Badgers Creek Road – one public and three school buses. The public bus route 801 runs three services in the AM peak and three in the PM peak. The two of the three school buses run once in the AM school peak and one run in the PM school peak.</p> <p>All drivers will be briefed to be aware of pedestrians alighting from buses and that buses are always given priority along the haul route.</p>
12/07/2023	4.1	Figure 3	Figure 3 updated for clarity
12/07/2023	5.1	There will be minimal impact on the surrounding road network as	PLM defines the AM peak as being between 7.30am – 8.30am

the vehicle numbers are significantly less for Stage 01 works before Stage 02 starts. The project vehicle number at peak is shown in Table 7 noting that PLM D&C defines the AM peak as being between 7.30am – 8.30am and PM peak as being 4.30am – 5.30am Monday to Friday which is consistent with the EIS defined AM and PM peaks.

Table 7 – Projected vehicle numbers

The EIS construction movement allocation on airport is categorised as:

- Airport Business Park
- On-airport construction corridor (Western Sydney International to Airport Business Park)
- On-airport construction corridor (Airport Business Park to Airport Terminal)
- On-airport construction corridor (Airport Terminal to Aerotropolis)
- Viaduct and tunnel segment yard

For ABP construction scope of work, it is assumed that the construction movements allocated to Airport Business Park and On-airport construction corridor (Western Sydney International to Airport Business Park) can be used.

To further mitigate the impact of PLM D&C vehicular traffic, PLM D&C has negotiated with AeroWest for continued access to the Location 1F LILLO access road until the end of 2026 so the bulk of ABP vehicles can avoid using the Location 1A roundabout. This also reduces the demand for vehicular access to Badgerys Creek Road from Elizabeth Drive

and PM peak as being 4.30am – 5.30am Monday to Friday which is consistent with the EIS defined AM and PM peaks. **The EIS construction movement allocation on airport is categorised into the following sites:**

- Airport Business Park
- On-airport construction corridor (Western Sydney International to Airport Business Park)
- On-airport construction corridor (Airport Business Park to Airport Terminal)
- On-airport construction corridor (Airport Terminal to Aerotropolis)
- Viaduct and tunnel segment yard

Following ABP Access Portion 01 handover, SBT will continue building the tunnel from ABP to ATL in Access portion 02 utilising the EIS construction movement allocation for On-airport construction corridor (Airport Business Park to Airport Terminal).

As PLM and SCAW share one access into Access Portions 02 and 03, they share the construction movement allocation for Airport Business Park and On-airport construction corridor (Western Sydney International to Airport Business Park).

The last of SCAW's planned sandstone deliveries will take place over 5 days in late August / early September when PLM will be undertaking site establishment works only. Following completion of sandstone deliveries SCAW will have minor works in Access Portion 03 only with 5 to 6 heavy vehicles and up to 20 light vehicles expected on site daily

as Location 1F can be more easily access from the northbound direction.

before handover in July 2024. SCAW also will not have a site compound within Access Portion 03 so SCAW light vehicle access to Access Portion 03 will be kept to a minimum for construction only.

The project vehicle number at peak is shown in Table 7 noting that the EIS peak numbers shown are for the combined total for Airport Business Park and On-airport construction corridor (Western Sydney International to Airport Business Park).

The PLM peak construction movements shown in Table 7 is the peak for the entire life of the ABP construction including all works within the scope of works.

Table 7 updated for clarity

As shown above, there will be minimal impact on the surrounding road network during AM and PM peaks as the project heavy and light vehicle demand is well within the EIS numbers for all phases of ABP and On-airport construction corridor (Western Sydney International to Airport Business Park) construction.

The site superintendent will ensure that the minimum number of vehicles possible is scheduled to come in during the EIS peak hours and given that there is a significant amount of vehicle storage area on site, release the minimum number of vehicles possible site during the EIS peak hours to minimise impact on the surrounding road network

Table 7

12/07/2023

6.1

100 parking spaces will be provided within Access Portion 01.

There is no pedestrian access between the site carparking area shown in Figure 11 and the work

80 parking spaces will be provided within Access Portion 01. There is a maximum of 80 workers on site at ABP within Access Portion 01 handover timeframe.

area on the alignment to the north. All workers will be transported between the work area and the carparking area via pool vehicles (mini-buses and utility vehicles).

Within the Access Portion 01 parking area there will be 20 carpool parking spaces assigned to the five 12-seater minibuses and ten pool utility vehicles that will be allocated to the ABP site during Access Portion 01 as there is no safe pedestrian access route between the car parking area and the work area north of the concrete batching plant. The work area north of the concrete batching plant will allow no car parking and the shared access road to the work area will not allow personal light vehicle access unless it is a pool vehicle.

There is no **safe** pedestrian access **for regular use** between the site carparking area shown in Figure 11 and the work area on the alignment to the north. All workers will be transported between the work area and the carparking area via pool vehicles (mini-buses and utility vehicles).

Within the Access Portion 01 parking area there will be 20 carpool parking spaces assigned to the five 12-seater minibuses and ten pool utility vehicles that will be allocated to the ABP site during Access Portion 01 as there is no safe pedestrian access route between the car parking area and the work area north of the concrete batching plant. The work area north of the concrete batching plant will allow no car parking and the shared access road to the work area will not allow personal light vehicle access unless it is a pool vehicle.

12/07/2023

7.4

An OSOM permit will be applied for Badgerys Creek Road through NVHR in consultation with Liverpool City Council.

No OSOM permit is required for the station construction scope within Access Portion 01. However if required PLM will apply for one through NVHR in consultation with Liverpool Council.

2 Executive Summary

Access to the Airport Business Park Station site will be handed over in three stages over a 12 month period. This CTMP covers the temporary traffic management for Access Portion 01 (projected handover in August 2023) and will be updated for the subsequent Access Portions following confirmation of handover information from SBT and SCAW for Access Portions 02 and 03.

3 Project Details

3.1 Proposed Works

The Airport Business Park Station is to deliver:

- Site establishment (including the relocation of a temporary concrete batching plant from within WSA footprint to Access Portion 01)
- Enabling works
- Construction of buildings:
 - Northern Service Building
 - Station (Platform) Building
 - Southern Service Building
 - Lifts and Stairways (Structure)
- Services to Station
- Rail Systems
- Station Precinct Works
 - Earthworks and drainage
 - Public utility and diversion works
 - Street lights and signs
 - Hard and soft landscaping and furniture

3.2 Site Location

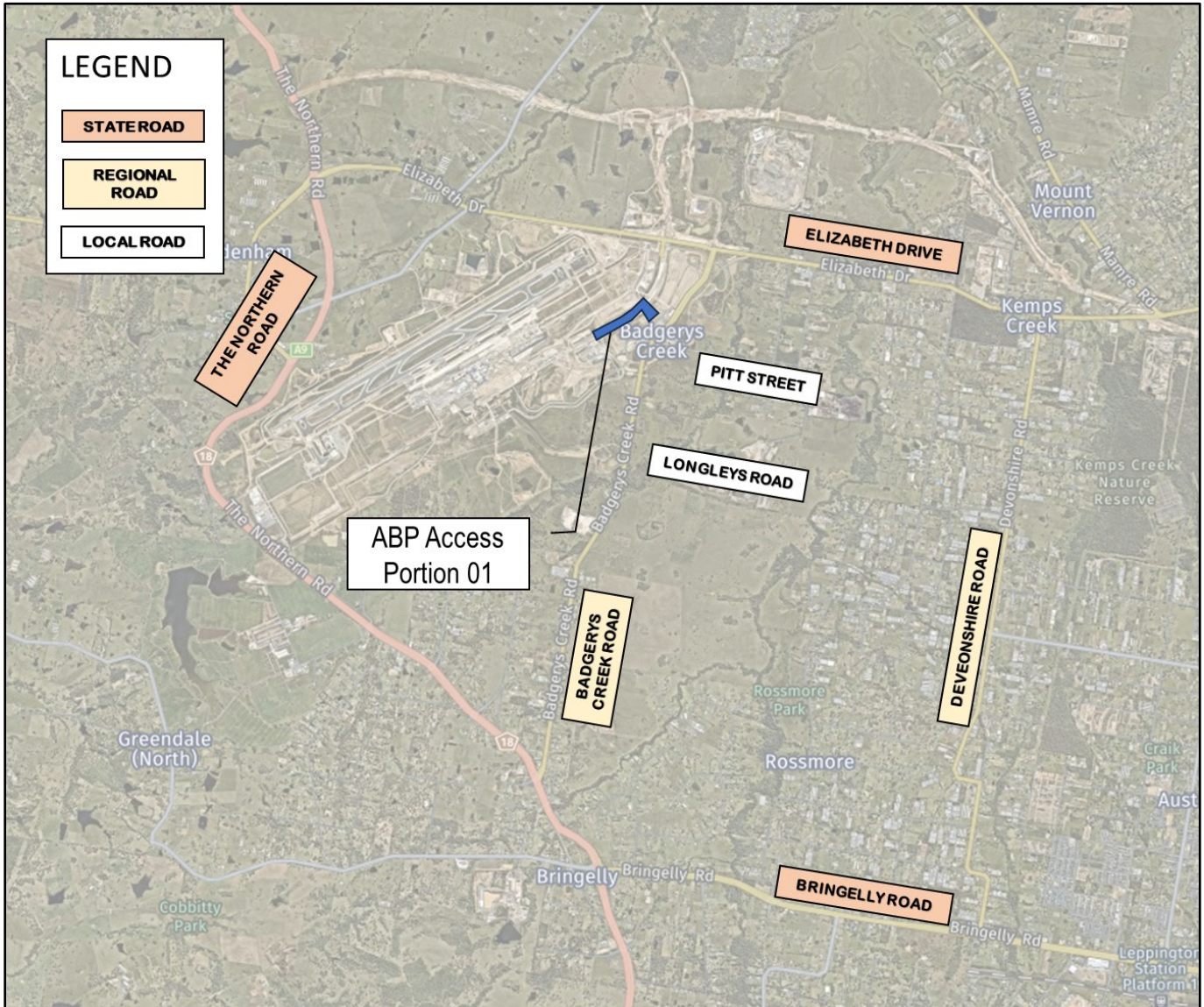

FIGURE 1: SITE LOCATION

The site is located within the Western Sydney Airport site. Access will be via Badgerys Creek Road, Badgerys Creek.

3.3 Timing of Works

The site will be handed over to SSTOM on 11th August 2023 with the site establishment works to commence on 11th August 2023.

TABLE 2: TIMING OF WORKS

Activity	Start Date	Finish Date
Stage 01: Site Establishment	11-Aug-23	11-Nov-23
Stage 02: Enabling Works	17-Nov-23	19-Apr-23
Stage 03: Station Structure	19-Apr-24	13-Mar-25
Station 04: Station and Finishing Works	19-Apr-24	14-Aug-25
Stage 05: Rail Construction	08-Oct-24	08-May-26
Stage 06: Precinct Works	13-Mar-25	08-May-26

3.4 Site Related Data

3.4.1 Road Details

The key roads surrounding the Site are identified within Figure 1 and summarised below:

TABLE 3: LOCAL ROAD NETWORK

Road Name	Section	Speed Limit	Parking	Traffic Volume and Peak Times	Urban / Rural
Badgerys Creek Road	Elizabeth Drive to The Northern Road	60km/hr - 80km/hr	No	-	Urban
Pitt Street	Intersection with Badgerys Creek Road	50km/hr	No	-	Rural
Elizabeth Drive	The Northern Road to Badgerys Creek Road	80km/hr	No	-	Urban

The Northern Road / A9	M4 to Badgerys Creek Road	80km/hr	No	-	Urban
Bringelly Road	M7 to The Northern Road	80km/hr	No	-	Urban

Note the AM / PM peaks on the road network is assumed to occur at 7.30am – 8.30am and 4.30pm – 5.30pm per the SSI-10051 EIS documentation.

3.4.2 Crash History

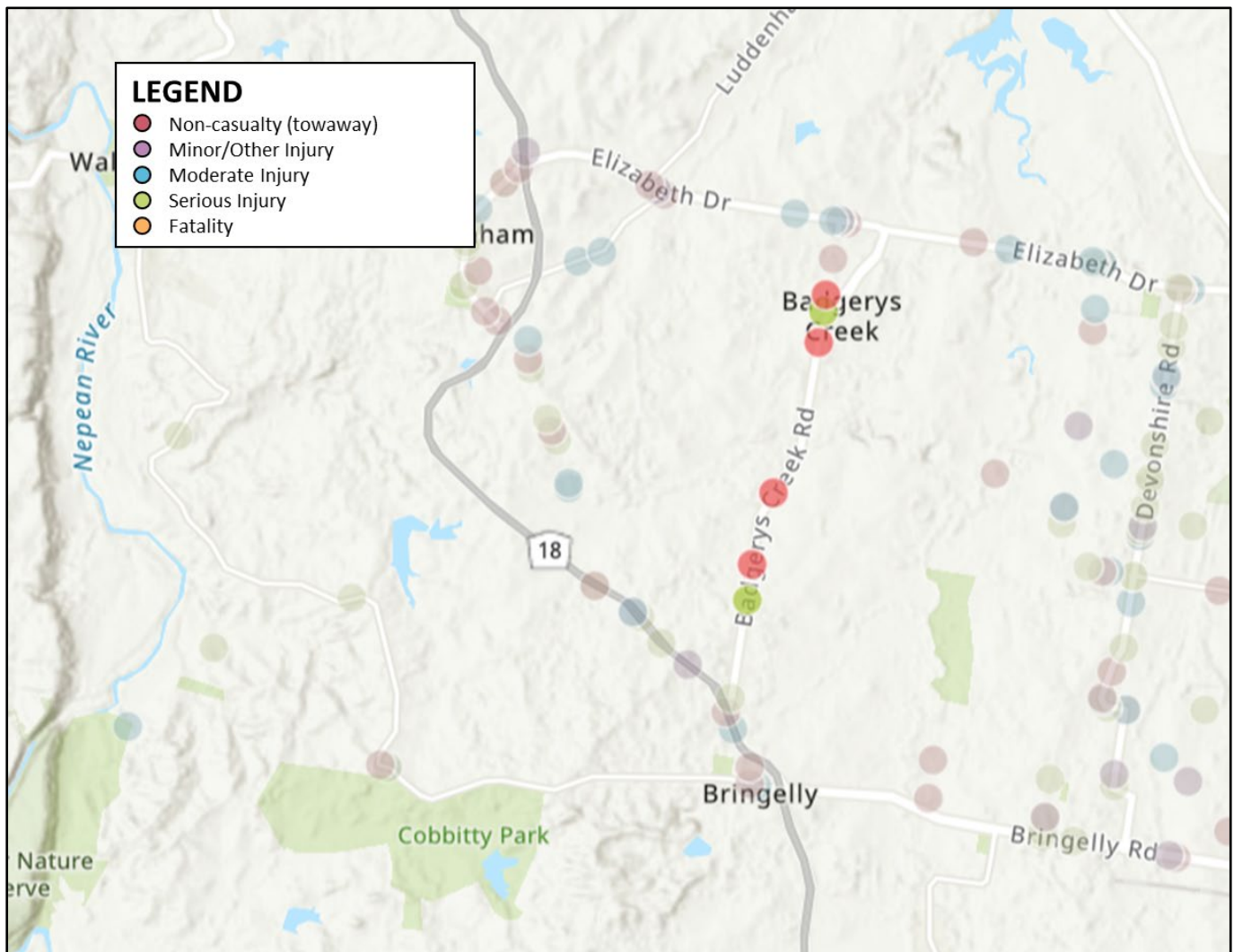

FIGURE 2: CRASH MAP

TABLE 4: CRASH HISTORY

Year	Location	RUM Code	Injury / Death
2018	Badgerys Creek Road near the Northern Road	30 – Rear end	Non-casualty (towaway)
2018	Badgerys Creek Road near the Northern Road	72 – Off road to right	Serious Injury (1)
2019	Badgerys Creek Road near Longleys Road	59 - Overtaking	Non-casualty (towaway)
2020	Badgerys Creek Road near Elizabeth Drive	67 – Struck animal	Non-casualty (towaway)
2021	Badgerys Creek Road near Jagelman Road	67 – Struck animal	Non-casualty (towaway)
2021	Badgerys Creek Road near Pitt Street	85 – Off rt/lft bnd=>obj	Serious Injury (1)
2021	Badgerys Creek Road near the Northern Road	71 – Off rd left => obj	Serious Injury (1)

An analysis of the crash history shows three crashes of the same type at Badgerys Creek Road near The Northern Road, however two of the crashes occurred prior to The Northern Road upgrade. As the Badgerys Creek Road and Elizabeth Drive upgrade is tied to the M12 and Western Sydney Airport construction, traffic conditions are expected to change significantly during this construction project.

3.4.3 Vulnerable Road Users

Vulnerable road users (VRU) are road users not in a car, bus or truck. In the event of a crash, VRUs have little to no protection from crash forces, therefore, need to be addressed within this CTMP. Table 5 provides context to VRU's surrounding the Site.

TABLE 5: PUBLIC AND ACTIVE TRANSPORT

Road Name	Pedestrian	Cycling	Public Transport
Badgerys Creek Road	Yes Footpath on either sides starting south of The Northern Road roundabout and end north of Pitt Street roundabout	No No on road cycleway, wide footpath on either sides starting south of The Northern Road roundabout and end north of Pitt Street roundabout	Yes – bus routes 801 (last stop north of Gardiners Road), 1014, 2017, 2053 (first stop south of Longleys Road) Bus stops along roadway at Longleys

			Road and Gardiners Road only.
Pitt Street	No	No No dedicated cycle / shared path	No
Elizabeth Drive	No	No No dedicated cycle / shared path	Yes – bus routes 801 (west of Badgerys Creek Road only), 4147, 4510, 9057, 9615, 9616 Bus stops along roadway
The Northern Road / A9	No consistent footpath provision. Some intermittent footpaths on both sides of the road.	No consistent cycleway provision off road. Some intermittent shared path on both sides of the road.	Yes – bus routes 789, 4005, 4611 and 4663 Bus stops along roadway
Bringelly Road	Yes Grade separated shared path on one side and intermittent footpath on other side	Yes Grade separated shared path on one side	Yes – 856, 1013, 1014, 1017, 1024, 1028, 1029, 1038, 1042, 1044, 2017, 2032, 2045, 2053, 2077 Bus stops along the roadway

4 Works Proposed

The construction at ABP is broadly separated into two packages:

- Station Construction (taking place within Access Portion 01)
- Rail Construction (taking place Access Portion 02 and 03)

4.1 Access Staging

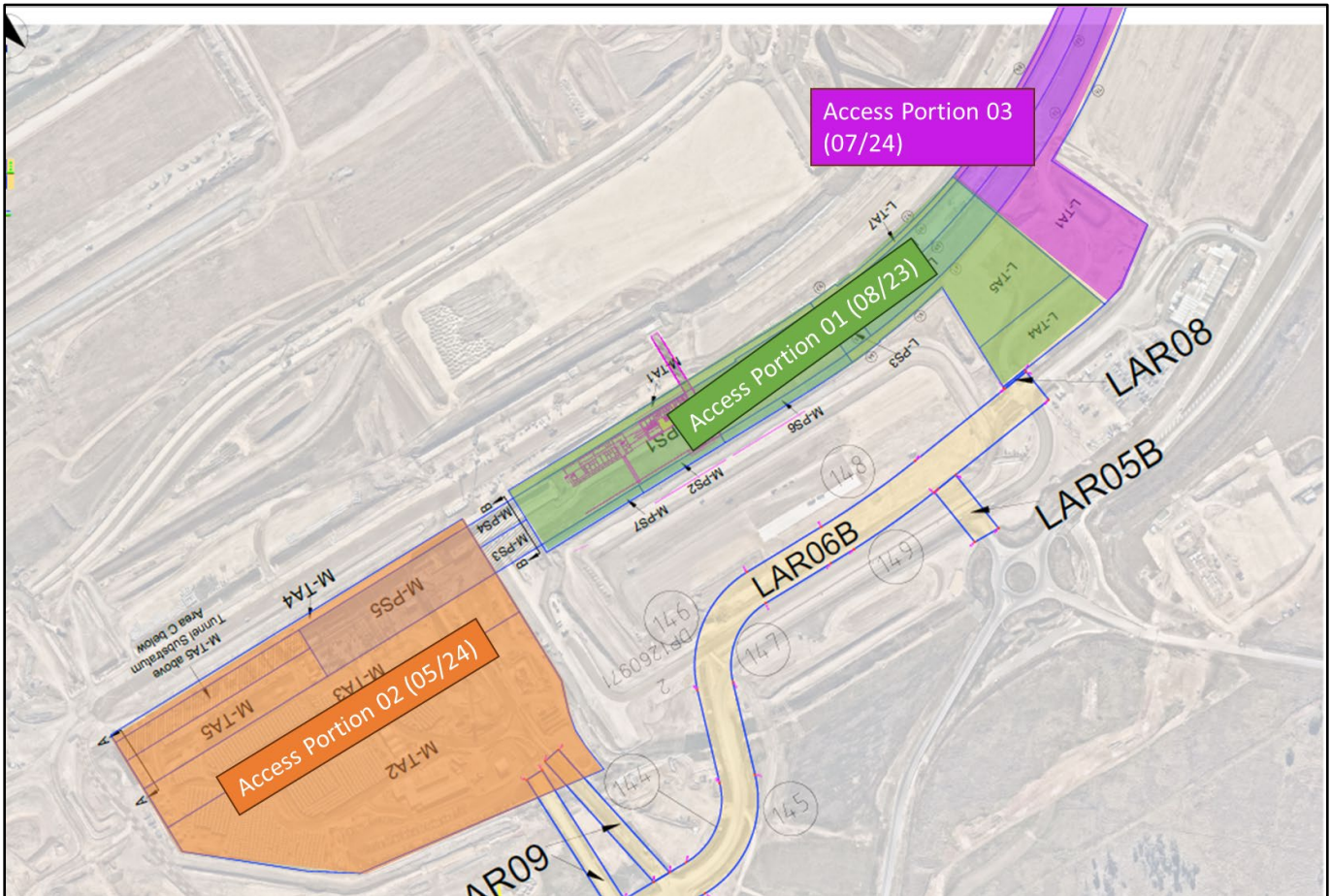

FIGURE 3: ABP ACCESS STAGING PLAN

The ABP Site is projected to be handed over to SSTOM in three portions with the first to be handed over in early August 2023. The second handover is projected to take place ten months after the first in May 2024 and the third two months after that in July 2023.

4.2 Station Construction

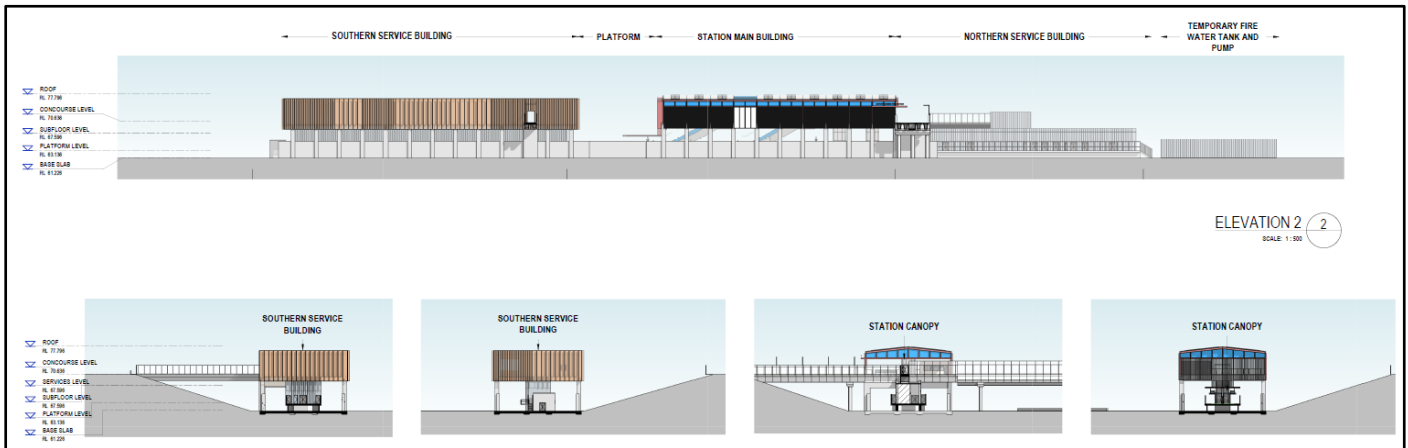

FIGURE 4: ABP STATION ARCHITECTURAL ELEVATIONS (PRELIMINARY)

The following key activities would be undertaken within this package:

- Site establishment (including the relocation of a temporary concrete batching plant from within WSA footprint to Access Portion 01)
- Enabling works
- Construction of buildings:
 - Northern Service Building
 - Station (Platform) Building
 - Southern Service Building
 - Lifts and Stairways (Structure)
- Services to Station
- Station Precinct Works
 - Earthworks and drainage
 - Public utility and diversion works
 - Street lights and signs
 - Hard and soft landscaping and furniture

4.3 Rail Construction

Rail construction is expected to start in October 2024 following SBT handover so that SSTOM is given access to the tunnel. This CTMP will be updated prior to rail construction package commencement.

4.4 Temporary Concrete Batching Plant

The WSA Terminal Contractor will be decommissioning their on-site temporary concrete batching plant as it is within the airport footprint and the supplier will be relocating the temporary concrete batching plant to within ABP Access Portion 01 (location per Figure 5). This batching plant is projected to be commissioned in April 2024.

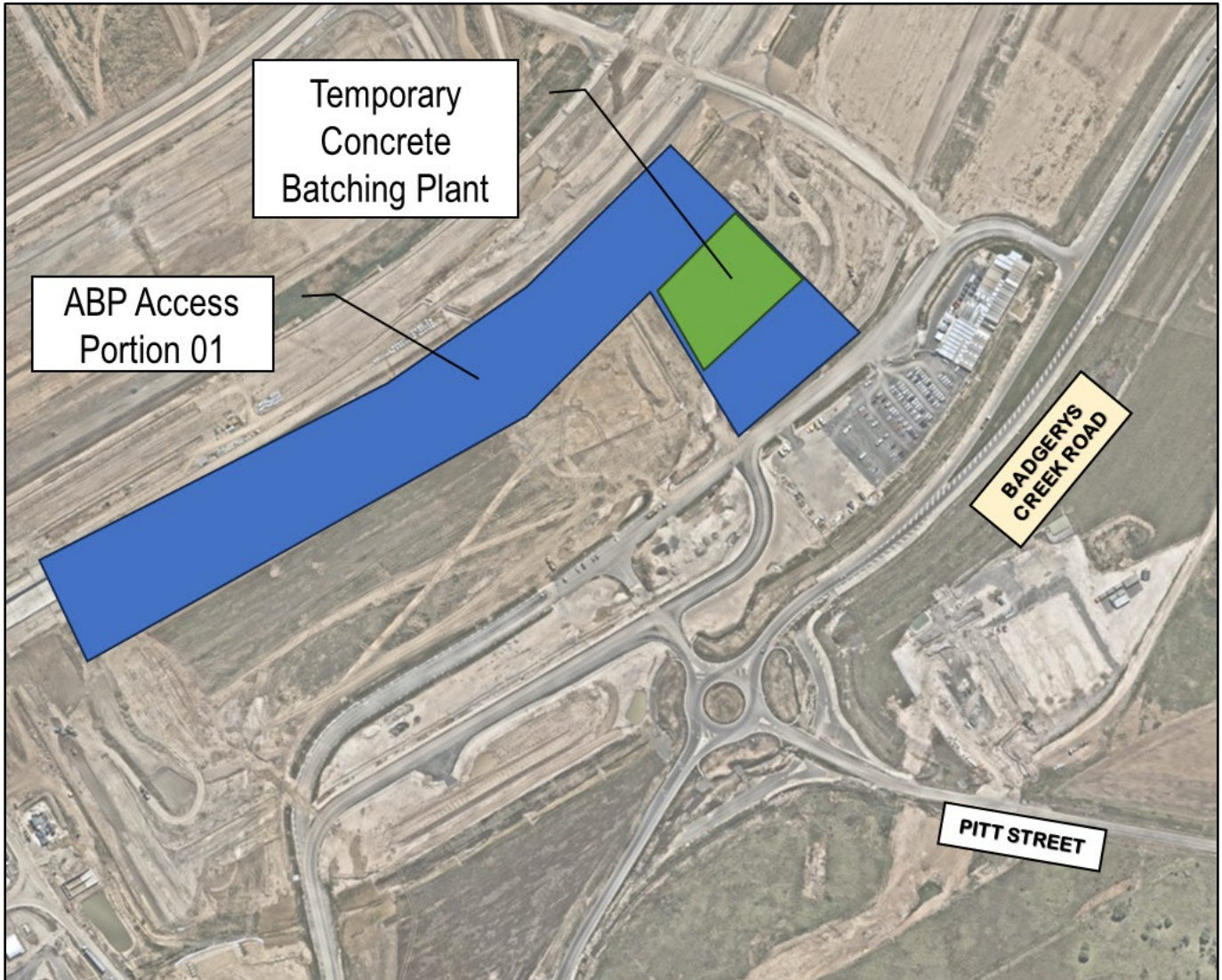

FIGURE 5: ABP TEMP CONCRETE BATCHING PLANT LOCATION

This temporary concrete batching plant will be supplying the construction works for ABP, Airport Terminal Station (ATL) and SSTOM Linewide (rail construction package) within the WSA site and Aerotropolis (AEC) Station off-airport.

4.5 Site Access

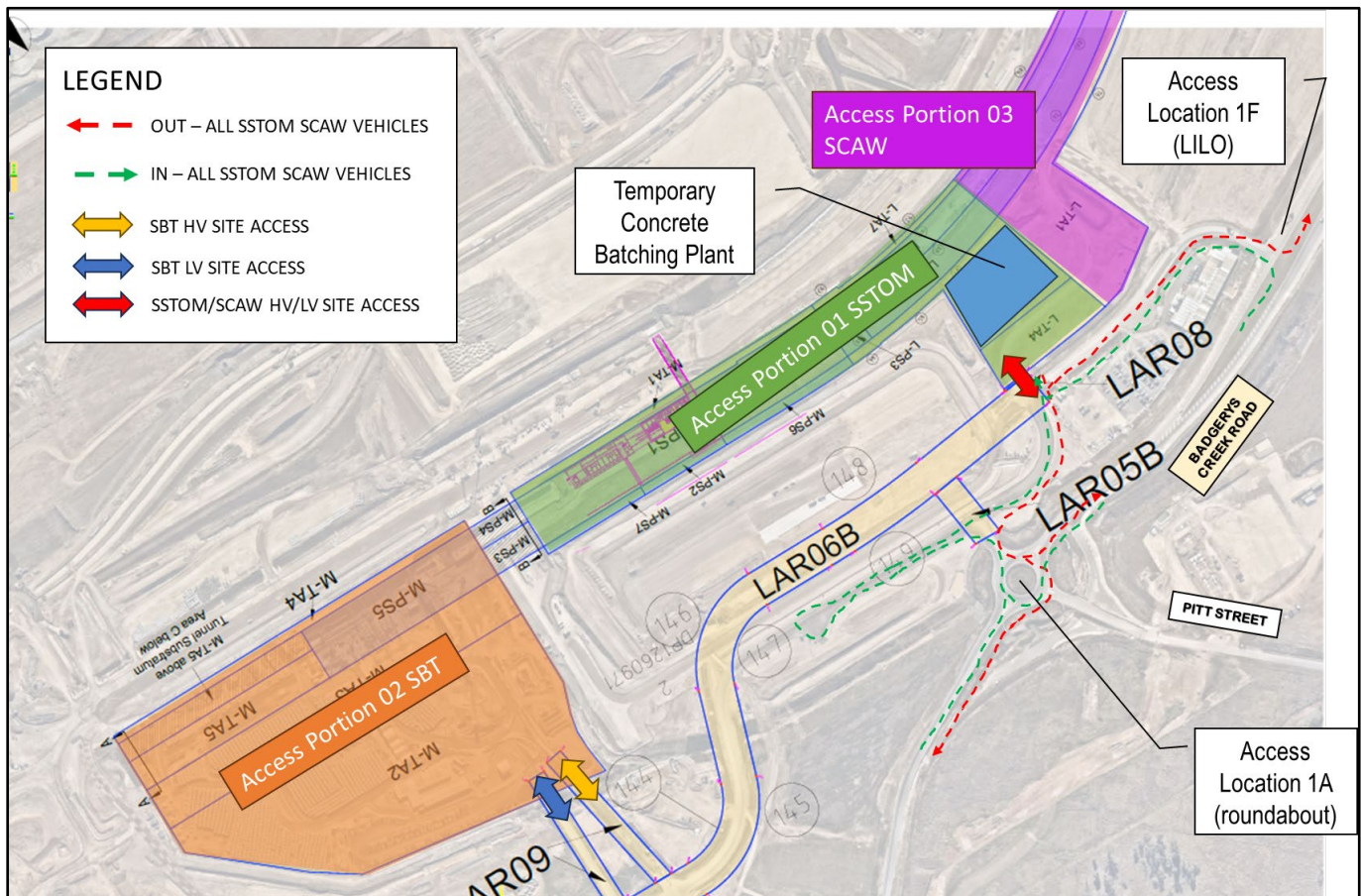

FIGURE 6: ABP SITE ACCESS

Site access for all SMWSA vehicles into WSA land will be off Badgerys Creek Road through either Location 1A (roundabout at intersection with Pitt Street) or Location 1F (left in / left out only access road north of Pitt Street). Note that before Access Portion 02 handover PLM and their subcontractors will minimise the use of Location 1A as much as possible to mitigate the cumulative traffic impacts on it. Prior to handover of Access Portion 02, access to ABP site for vehicles is significantly easier through Location 1F instead of Location 1A. Additionally, prioritization of Location 1F access this will be reinforced through site inductions, toolbox talks and the Driver's Code of Conduct.

Access to Access Portion 01 and 03 for both SSTOM and SCAW will be off WSA LAR 08 with right in / left out from the north (Location 1F) prioritised.

SBT access to Access Portion 02 will be through Location 1A only and accessing the site off LAR09. SBT access to Access Portion 02 is entirely independent of Access Portion 01/03.

Following handover of Access Portion 02, SSTOM access for the Linewide tunnel works will be through the existing SBT access. Similarly following Access Portion 03 from SCAW, SSTOM will use the LAR09 SBT access shown on Figure 6 for Linewide at grade construction.

4.6 Construction Hours

Construction hours have been outlined below per WSA00-WSA-00000-CN-PLN-000001 Construction Plan Rev 5 Section 3.3.2:

TABLE 6: CONSTRUCTION HOURS

Activity	Day	Time
Construction Works	Mondays to Fridays	7:00am to 6:00pm
	Saturdays	8:00am to 1:00pm
	Sundays or Public Holidays	At no time

It is not anticipated that construction works will be conducted outside of the hours outlined above. Should out of work hours be required, per Section 10.2 of WSA00-WSA-00400-EN-PLN-000002_NV CEMP (Rev 4), PLM will submit WSA00-WSA-00400-EN-FRM-000005 to the WSA Environment Team for review and approval by the WSA Environment Manager (or nominated delegate).

4.7 Construction Vehicle Movements

4.7.1 Truck Vehicle Volume

The projected daily heavy vehicle volume for all stages of ABP construction and temporary concrete batching plant is shown in Figure 7.

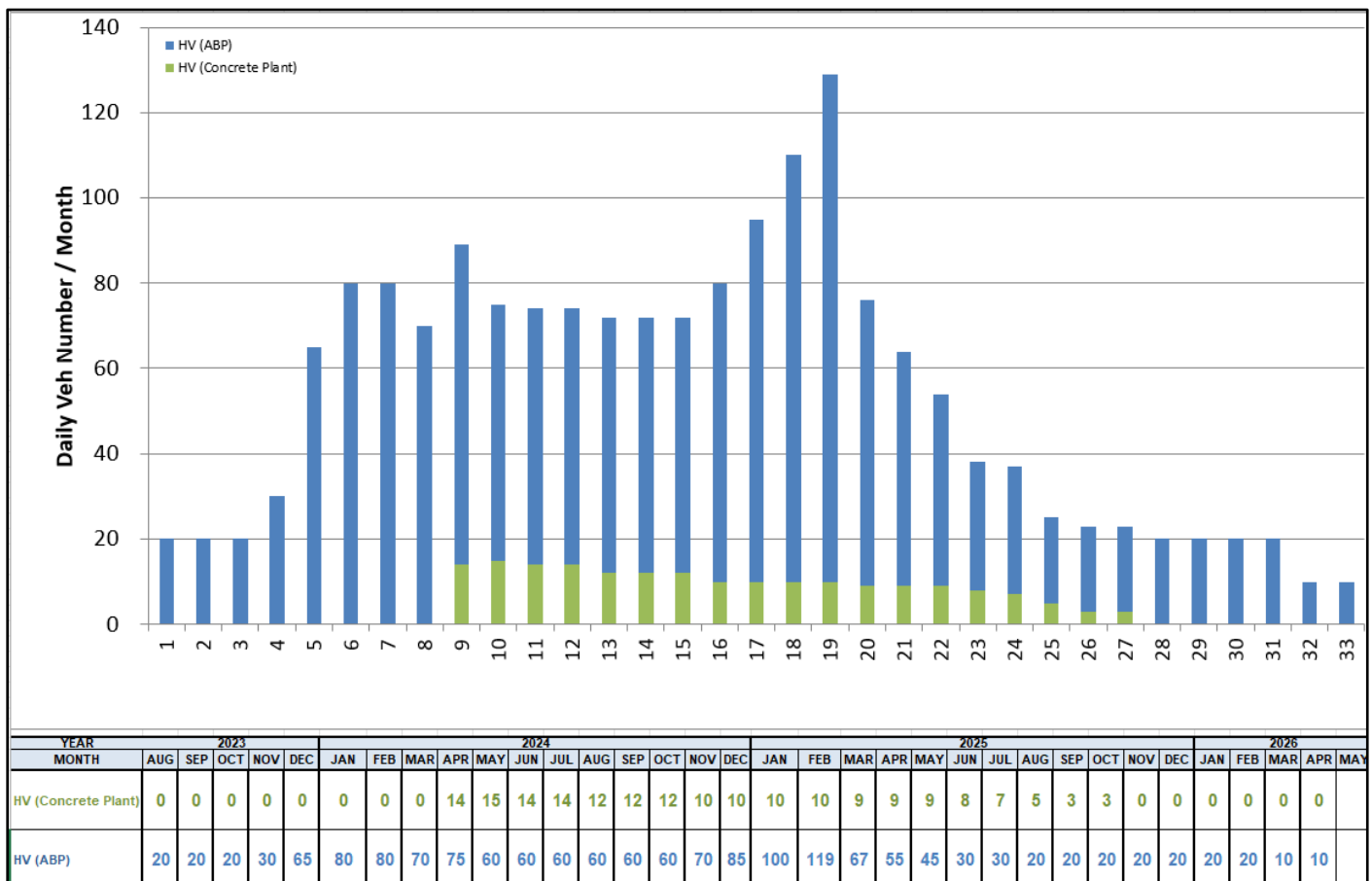

FIGURE 7: PROJECTED ABP HV NUMBERS

The anticipated heavy vehicle volume peak will start in January 2024 and drops off following completion of station finishing works in April 2025.

4.7.2 Truck Routes

It is proposed that all construction vehicles would enter and exit the Site via the routes shown in Figure 8. The routes shown are compliant with the EIS haul road routes and are to be utilised by all construction vehicles travelling to and from the site and represents the shortest route available from / to a State Road – hence minimising the impacts of the construction process. A copy of the approved routes will be distributed by PLM D&C to all drivers before their arrival to Site.

The largest truck required for ABP construction will be 19m long Articulated Vehicles (19m AV) so an over-size over mass (OSOM) permit will not be required for heavy vehicle access to site through Badgerys Creek Road. In the case that an OSOM permit is required, PLM D&C will obtain it from the National Heavy Vehicle Register (NHVR).

The swept paths (attached in Appendix A) demonstrate all critical turns at along the route shown in Figure 8. All delivery / construction vehicles will drive forward in and out of the Site onto Badgerys Creek Road via the existing WSA shared access roads. Note all access to all three Access Portions would be through either the Location 1A (Pitt Street roundabout) or Location 1F (access road LILO) per Figure 6.

There is a shared path on either side of Badgerys Creek Road starting south of the Elizabeth Dr intersection and stopping north of the Pitt Street intersection separated from the traffic lane by a wide shoulder. There are also bus stops along Badgerys Creek Road. PLM will be sharing the existing accesses to WSA site off Badgerys Creek Road and will be adhering to all existing pedestrian / cyclist / public transport impact management measures.

If any access to existing properties is affected by construction vehicle access to site, traffic controllers or appropriate traffic management would be available on the accesses to direct existing property users while guiding construction vehicles.

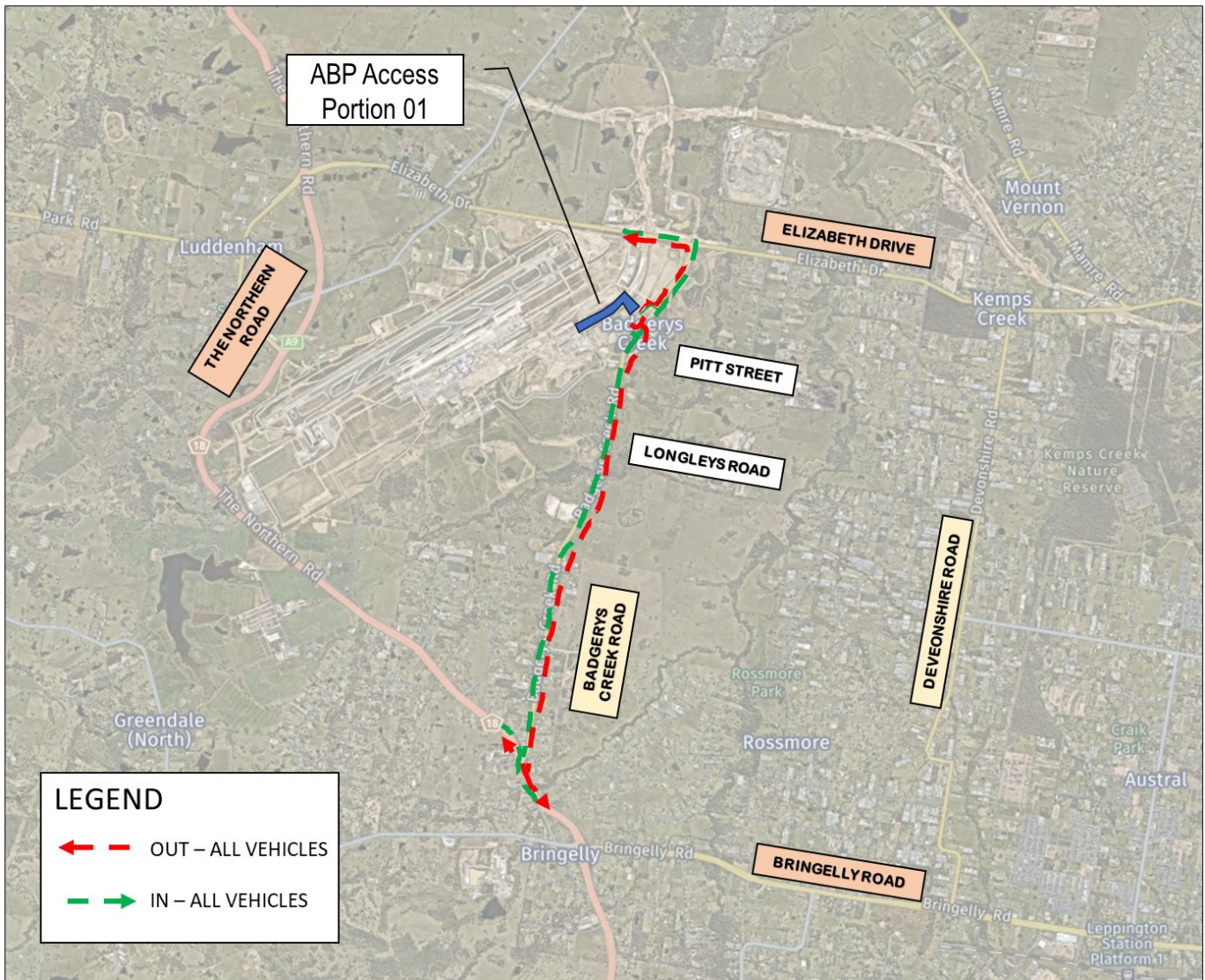

FIGURE 8: CONSTRUCTION VEHICLE ACCESS ROUTE

4.8 Temporary Traffic Management Method

4.8.1 Access Portion 01

All works related to ABP construction will take place within the WSA site and accessed through existing shared access roads in accordance with the sub-Shared Access Road Protocol (sub-SARP) in place for each access road.

Swept path assessments in Figure 9 show that the largest size heavy vehicle can access the site simultaneously without impacting Badgerys Creek Road at Location 1A. Note that the current sub-SARP for this access is that all vehicles entering are to turn left only to go south and use the p-turn to go north.

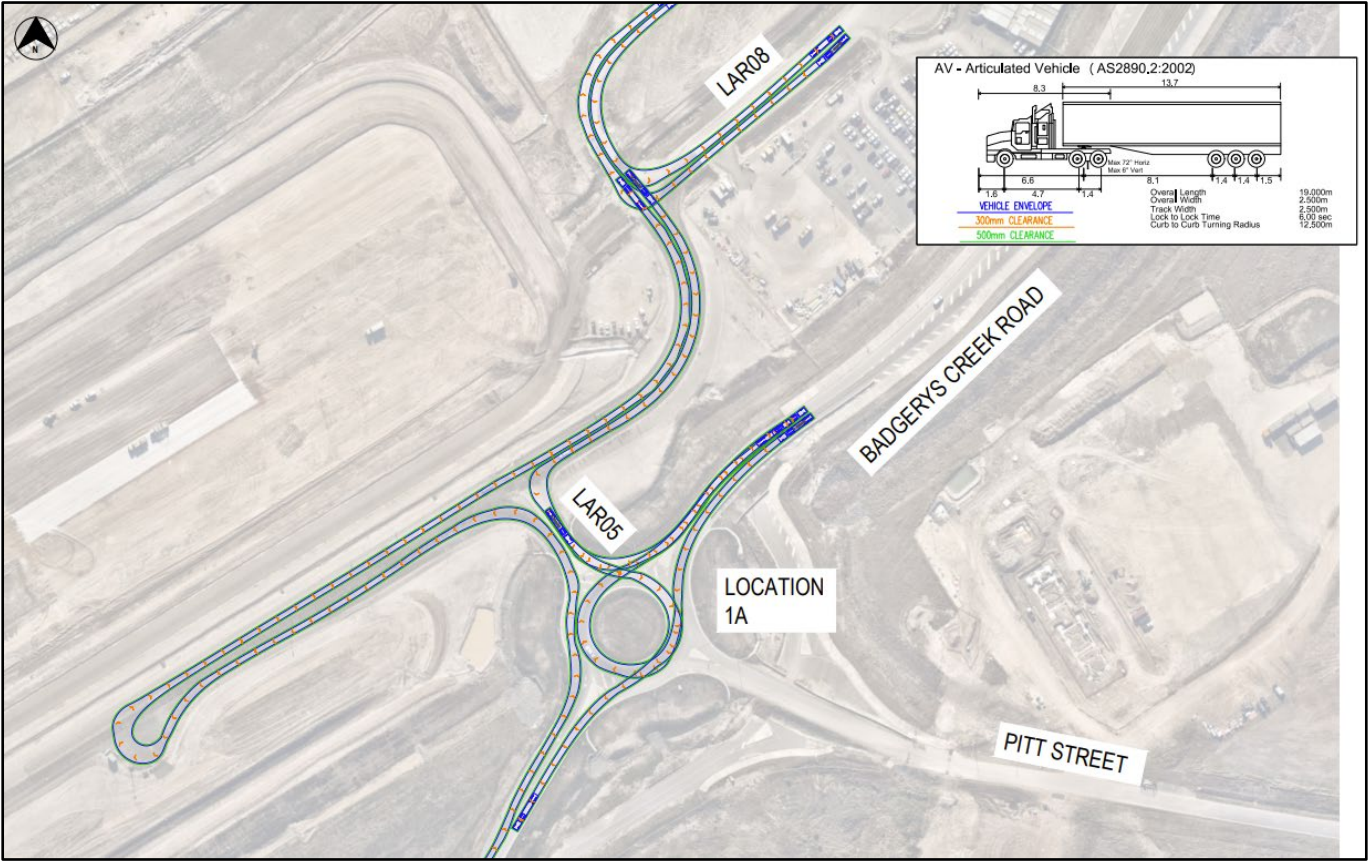

FIGURE 9: 19M AV ACCESS THROUGH LOCATION 1A

Similarly, 19m AV access to the access road from Badgerys Creek Road through Location 1F will not impact the existing operations of either roads per swept paths show in Figure 10.

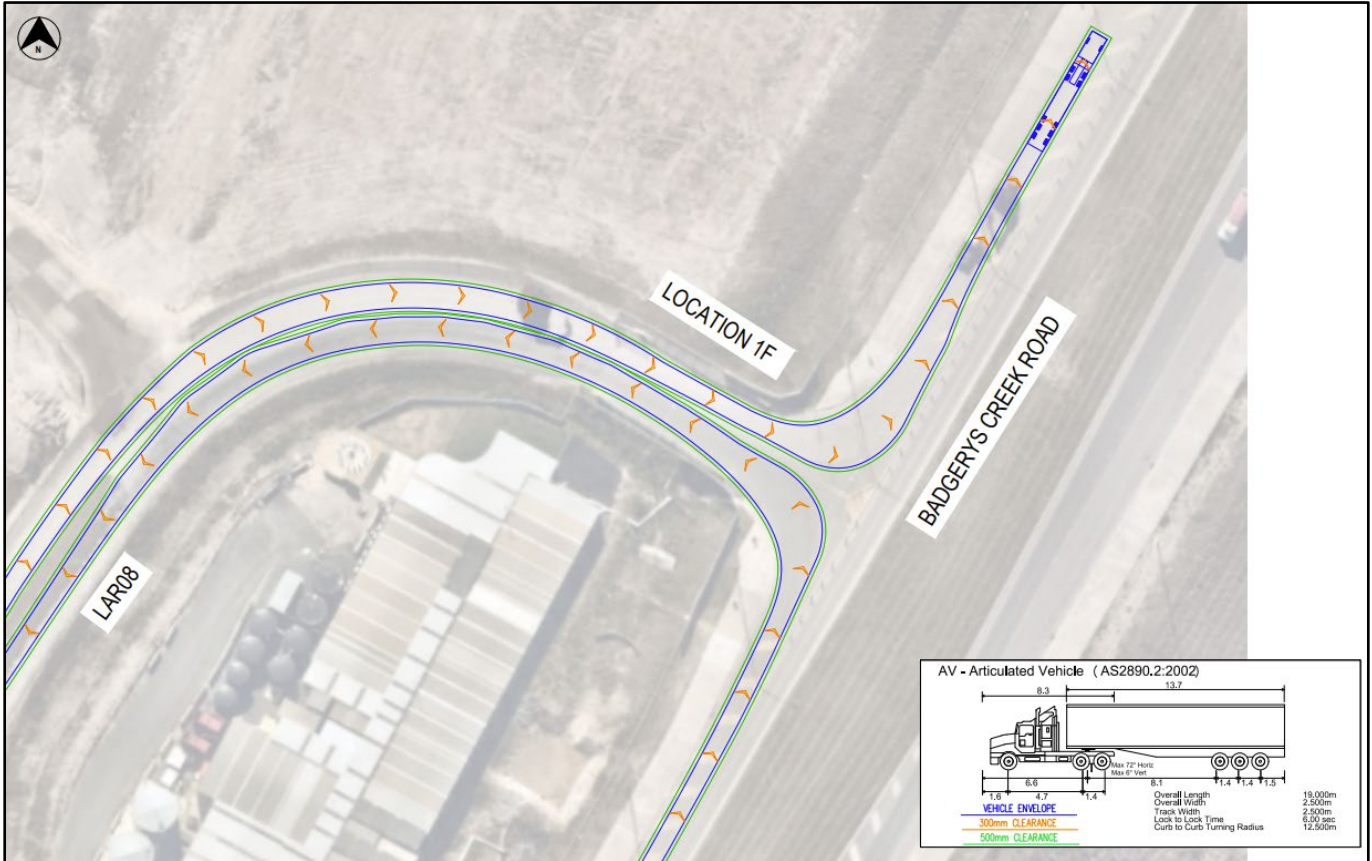

FIGURE 10: 19M AV ACCESS THROUGH LOCATION 1F

Given that PLM D&C will be sharing the use of existing access locations along Badgerys Creek Road and the existing construction ongoing at the WSA site, PLM D&C is not proposing any additional traffic control at either Location 1A or Location 1F.

PLM D&C will be utilising existing shared access roads within the WSA site and will not be proposing any additional traffic control within the site unless requested by adjacent contractors or following handover of Access Portions 02 and 03.

If required, Traffic Guidance Schemes will be prepared to meet the requirements outlined in TfNSW Traffic Control At Work Sites Technical Manual (Issue 6.1, 2022).

4.8.2 Access Portion 02 and 03

Deliveries of rail segments for Stage 02 construction of the rail infrastructure is expected to start in July 2024 which will necessitate deliveries utilizing Class 01 or 03 heavy vehicles.

Temporary traffic management arrangements will change to accommodate the additional accesses and this CTMP will be updated following confirmation of handover information from SBT and SCAW for Access Portions 02 and 03.

4.9 Risk Assessment

A risk assessment is aimed to identify the hazards and risks associated with the works. The purpose of this risk assessment is to determine the controls required for the protection of the road workers and road users. A Risk assessment has been completed and is attached in Appendix B.

5 Traffic Impact Management

5.1 Vehicle Impact Management

PLM defines the AM peak as being between 7.30am – 8.30am and PM peak as being 4.30am – 5.30am Monday to Friday which is consistent with the EIS defined AM and PM peaks. The EIS construction movement allocation on airport is categorised into the following sites:

- Airport Business Park
- On-airport construction corridor (Western Sydney International to Airport Business Park)
- On-airport construction corridor (Airport Business Park to Airport Terminal)
- On-airport construction corridor (Airport Terminal to Aerotropolis)
- Viaduct and tunnel segment yard

Following ABP Access Portion 01 handover, SBT will continue building the tunnel from ABP to ATL in Access portion 02 utilising the EIS construction movement allocation for On-airport construction corridor (Airport Business Park to Airport Terminal).

As PLM and SCAW share one access into Access Portions 02 and 03, they share the construction movement allocation for Airport Business Park and On-airport construction corridor (Western Sydney International to Airport Business Park).

The last of SCAW's planned sandstone deliveries will take place over 5 days in late August / early September when PLM will be undertaking site establishment works only. Following completion of sandstone deliveries SCAW will have minor works in Access Portion 03 only with 5 to 6 heavy vehicles and up to 20 light vehicles expected on site daily before handover in July 2024. SCAW also will not have a site compound within Access Portion 03 so SCAW light vehicle access to Access Portion 03 will be kept to a minimum for construction only.

The project vehicle number at peak is shown in Table 7 noting that the EIS peak numbers shown are for the combined total for Airport Business Park and On-airport construction corridor (Western Sydney International to Airport Business Park).

The PLM peak construction movements shown in Table 7 is the peak for the entire life of the ABP construction including all works within the scope of works.

TABLE 7: PROJECTED VEHICLE NUMBERS

Vehicle Type	IN	OUT	TOTAL	IN	OUT	TOTAL
	EIS AM Peak Construction Movements (Airport Business Park and On-airport construction corridor, WSA to ABP)			EIS PM Peak Construction Movements (Airport Business Park and On-airport construction corridor, WSA to ABP)		
LV Staff	213+48= 261	0+0= 0	261	0+0= 0	213+48= 261	261
LV Deliveries	1+1= 2	1+1= 2	4	1+1= 2	1+1= 2	4
HV	6+10= 16	6+10= 16	32	6+10= 16	6+10= 16	32
	PLM AM Peak Construction Movements (following complete handover)			PLM PM Peak Construction Movements (following complete handover)		

LV Staff	50	0	50	0	100	100
LV Deliveries	2	2	4	2	2	4
HV	12	12	24	12	12	24

As shown above, there will be minimal impact on the surrounding road network during AM and PM peaks as the project heavy and light vehicle demand is well within the EIS numbers for all phases of ABP and On-airport construction corridor (Western Sydney International to Airport Business Park) construction.

To further mitigate the impact of PLM D&C vehicular traffic, PLM D&C has negotiated with AeroWest for continued access to the Location 1F LILO access road until the end of 2026 so the bulk of ABP vehicles can avoid using the Location 1A roundabout. This also reduces the demand for vehicular access to Badgerys Creek Road from Elizabeth Drive as Location 1F can be more easily access from the northbound direction.

The site superintendent will ensure that the minimum number of vehicles possible is scheduled to come in during the EIS peak hours and given that there is a significant amount of vehicle storage area on site, release the minimum number of vehicles possible site during the EIS peak hours to minimise impact on the surrounding road network.

5.2 Pedestrian / Cyclist Impact Management

There is a shared path on either side of Badgerys Creek Road starting south of the Elizabeth Dr intersection and stopping north of the Pitt Street intersection separated from the traffic lane by a wide shoulder. PLM D&C will be sharing the existing accesses to WSA site off Badgerys Creek Road and will be adhering to all existing pedestrian / cyclist impact management measures.

Note that all drivers accessing the site will be licenced and briefed via the induction and daily toolbox talks to be aware of pedestrians and / or cyclists at all times. This is further reinforced in the Drivers' Code of Conduct (see Appendix E).

5.3 Public Transport Impact Management

There are four bus routes on Badgers Creek Road – one public and three school buses. The public bus route 801 runs three services in the AM peak and three in the PM peak. The two of the three school buses run once in the AM school peak and one run in the PM school peak.

All drivers will be briefed to be aware of pedestrians alighting from buses and that buses are always given priority along the haul route.

5.4 Property and Utility Access Impact Management

Access to the residential properties along Badgerys Creek Road will be maintained at all times and access for utilities providers / maintainers will not be impacted.

5.5 Cumulative Impacts

Between August 2023 and May 2024, PLM D&C will be sharing the ABP site with both SCAW and SBT. Weekly coordination meetings between the site superintendents from SCAW, SBT and SSTOM (PLM D&C) to ensure the vehicular impact of all three sites will not affect Badgerys Creek Road.

PLM D&C traffic management will ensure the vehicle generation numbers (heavy and light) will be within the numbers identified in the EIS. All vehicular access to the ABP site will be registered a week in advance on the PLM logistics software to apply for a loading slot and a time or a parking space. The site superintendent will manage the applications to ensure vehicle generation numbers stay within the identified limits in the EIS. The same software will retain the vehicle data per SSI condition E108.

PLM D&C traffic management is an active participant in the TTLG, TCG and the TCWG meetings ensuring ongoing monitoring and discussion will occur over the life of the project. Coordination with Western Sydney Airport and Transport for NSW would be undertaken through the TTLG and to manage potential cumulative construction traffic impacts with M12 Motorway and Elizabeth Drive.

5.6 Authorised Traffic Controller

No traffic controller is required at the interface between WSA land and Badgerys Creek Road.

If traffic controllers are required within site, whilst on Site, the responsibilities of the Traffic Controller include:

- Implementation of the Traffic Guidance Scheme.
- Pedestrian and cyclist management, to ensure that adverse conflicts between vehicle movements and pedestrians do not occur.
- Supervision of all loading and unloading of construction materials during the deliveries in the construction phase of the project.

6 Parking Management

There will be no contractor parking allowed on Badgerys Creek Road.

Following complete handover of the ABP Site, there will be 240 parking spaces provided on site.

All visitors to Site will arrange the visit with PLM D&C and be picked up by minibus or pool car from a centralised location (Railway Station or another pre-arranged location) to be transported to Site.

Subcontractors will have to register their carpark requirements with PLM D&C prior to starting on-site and will be encouraged to carpool noting that secure tool storage areas and amenities will be available within the Site.

PLM D&C will ensure that all personnel, including sub-contractors are aware of the specific requirements of TfNSW customers, general public, residents and businesses, prior to attending site through the induction process and regular updates through tool-box talks.

6.1 Access Portion 01

80 parking spaces will be provided within Access Portion 01. There is a maximum of 80 workers on site at ABP within Access Portion 01 handover.

There is no pedestrian access between the site carparking area shown in Figure 11 and the work area on the alignment to the north. All workers will be transported between the work area and the carparking area via pool vehicles (mini-buses and utility vehicles).

Within the Access Portion 01 parking area there will be 20 carpool parking spaces assigned to the five 12-seater minibuses and ten pool utility vehicles that will be allocated to the ABP site during Access Portion 01 as there is no safe pedestrian access route between the car parking area and the work area north of the concrete batching plant. The work area north of the concrete batching plant will allow no car parking and the shared access road to the work area will not allow personal light vehicle access unless it is a pool vehicle.

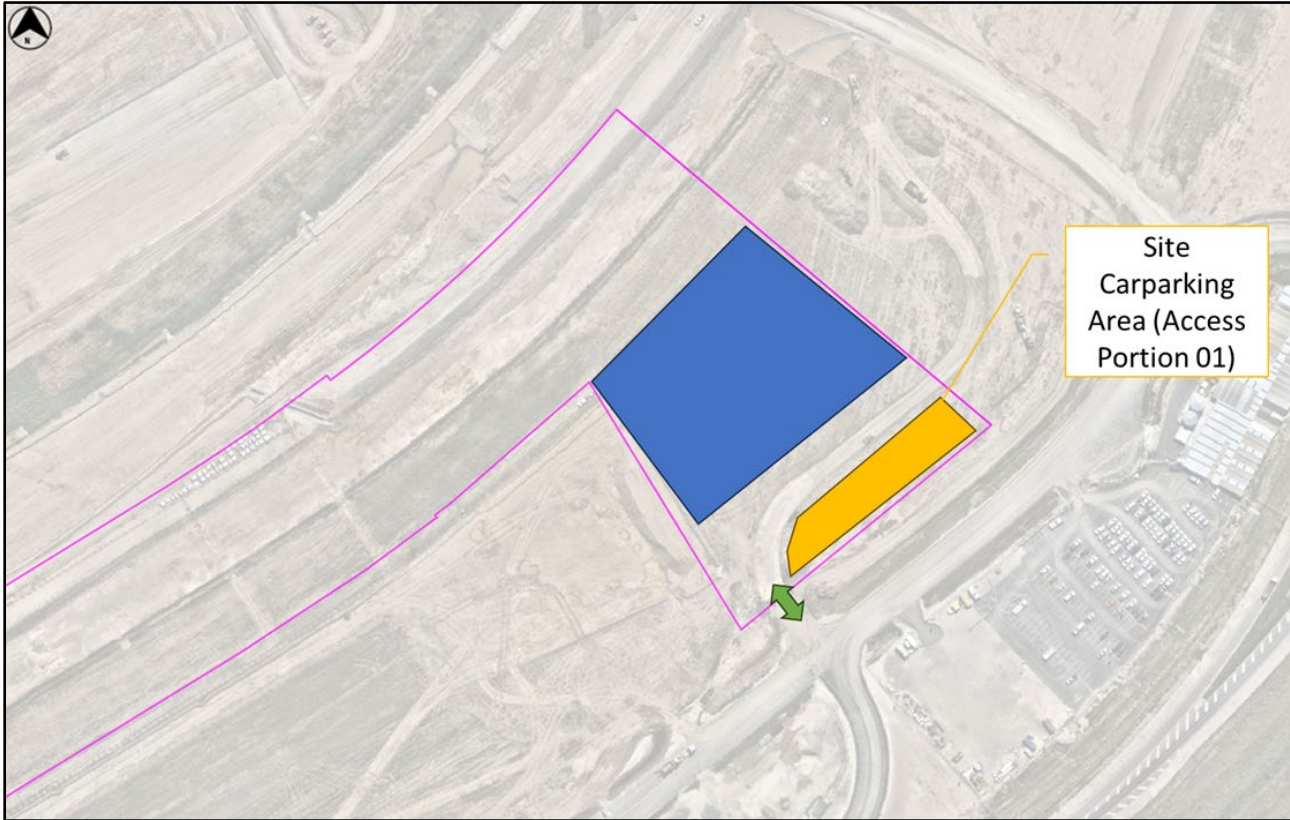

FIGURE 11: PROPOSED ACCESS PORTION 01 PARKING PLAN

Subcontractors can register carpool vehicles to be allocated parking within the Carpool Parking Area. There will be limited capacity for pick up and drop off to public transport from Site in the mornings and afternoon via the pool vehicles.

6.2 Access Portion 02 and 03

PLM D&C will be taking over the existing SBT car parking area within Access Portion 02 which will be able to accommodate another 140 cars.

SBT Carparking
Access (Access
Portion 02)

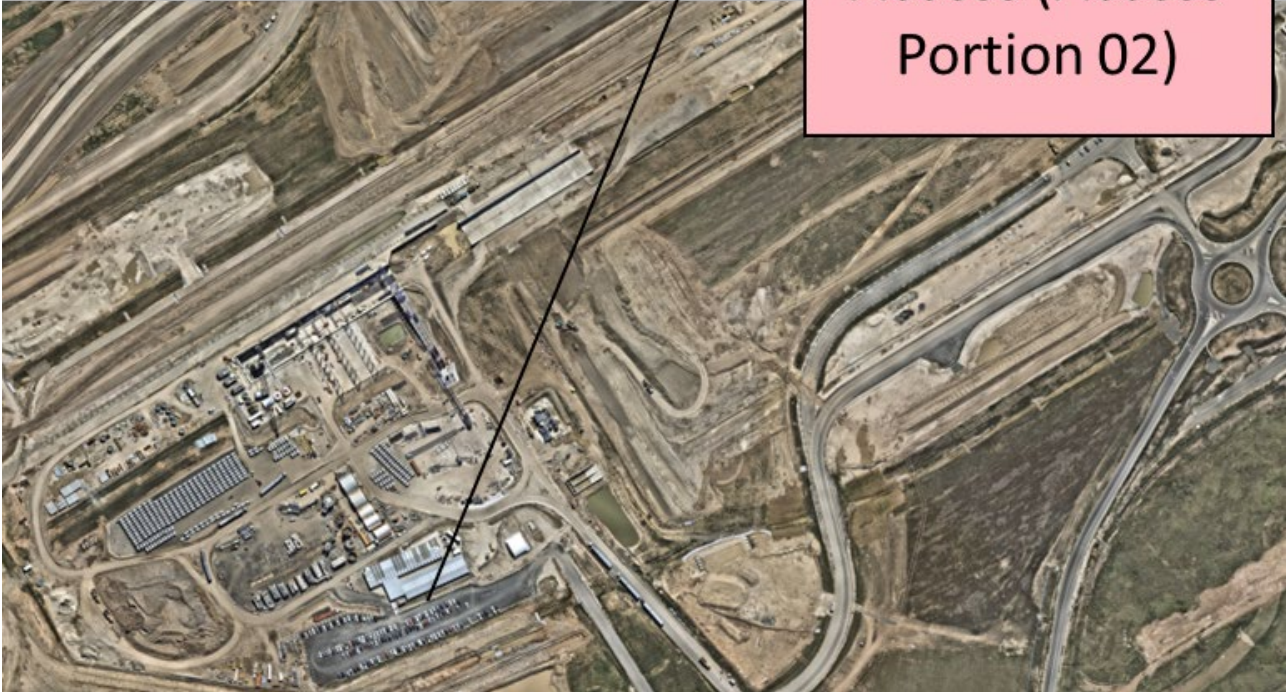

FIGURE 12: ACCESS PORTION 02 CARPARKING

Sub contractors will be allocated parking to one of two carparks depending on work and location requirements. Following Access Portion 02 and 03 handover the pool vehicles allocated to ABP will reduce as safe pedestrian access routes will be available with the additional portions.

7 Agency Permits

7.1 Council Permits

No Council permits is required for works on WSA land.

7.2 Local Traffic Committee

No works proposed in this CTMP will trigger a Local Traffic Committee referral.

7.3 Road Dilapidation Report

Before any local road, is used by Heavy Vehicles, a Road Dilapidation Report will be prepared. A copy of that report will be provided to Liverpool City Council within three (3) weeks of completion of the survey and no later than one (1) month before the road is used by Heavy Vehicles associated with the project.

If damage to roads occurs as a result of the construction of the project PLM D&C will either (at Liverpool City Council's discretion):

- Compensate Liverpool City Council for the damage so caused or
- Rectify the damage to restore the road to at least the condition it was in pre-work as identified in the Road Dilapidation Report

7.4 OSOM Permits

No OSOM permit is required for the station construction scope within Access Portion 01. However if required PLM will apply for one through NVHR in consultation with Liverpool Council.

7.5 Speed Zone Authorisation Permits

No SZA permit is required for ABP works.

7.6 Western Sydney Airport Building Approval Number

This CTMP will be submitted as part of PLM's first Western Sydney Airport Building Approval Number (SSTOM BAN 01) submission.

8 Community Notification

PLM JV will be responsible for the dissemination of information to the community including affected residents, relevant Councils, businesses and the public.

8.1 Site Contact

The current site contact for the works identified in this CTMP is:

Ian Baldwin (Site Superintendent): 0428 085 501

8.2 Propose Communications

- Community Notices (Notifications) issued at least 7 days prior to:
 - start of work
 - new work with a new activity that has the potential to impact on stakeholders and the community
 - handover of a construction site to a new contractor
 - activities requiring notification to comply with relevant Environmental Protection Licence (EPL) usually out of hours work.
- Precinct updates/e-update (Newsletters) - published 2x/year and for changes to planning approvals
- Email and internet updates – done with publication and delivery to letterboxes of Notifications and Newsletters.
- Advertisements – published in advance of significant traffic management changes, detours, traffic disruptions
- Advance warning sign – as noted in the CTMP, where required

Table 8 provides the proposed communications to be implemented for this CTMP.

TABLE 8: PROPOSED COMMUNICATIONS

Notification	Stage 01
Community Notice	Yes
Precinct Update / e-updated	Yes
Email	Yes
Internet	Yes
Print Advertising	Yes
Advance Warning Sign	Yes

8.3 Travelling Public

Where the SSTOM works will impact on the travelling public, PLM D&C will undertake the following communications:

- Motoring public will be forewarned of any changes including road closures, road changes and lane changes well in advance using appropriate signs including Variable Message Signs (VMS)
- Active transport users will be provided with advance warning signs.

8.4 Variable Message Signs

Variable message signs are not required for Stage 01 works.

If they are required at any stage of the project, they will be installed 7 days prior to any change to existing traffic conditions and per TfNSW “Instructions for the use of portable variable message signs: May 2021”.

8.5 Stakeholders

PLM D&C will liaise with relevant stakeholders regarding all relevant construction traffic management measures and will raise any potential conflict with stakeholder at the earliest time.

This will be done through the following groups:

- Traffic and Transport Liaison Group (TTLG)
- Traffic Control Group (TCG)
- Luddenham Traffic Working Group

There are a number of stakeholders PLM D&C will consult with during the development of this CTMP:

- Customer Journey Planning (CJP)
- Sydney Metro project team
- Penrith City Council (PCC)
- Transport for NSW (TfNSW)

A copy of their review comments will be provided in Appendix C.

9 Monitoring and Review

9.1 Road Safety Audit

Road safety audits will be undertaken during the development and implementation of the CTMP. The audits will be undertaken as noted in the section 10 of the Construction Traffic Management Framework. A copy of the road safety audits is provided in Appendix D.

9.2 Monitoring Program

This CTMP shall be subject to ongoing review and will be updated accordingly. Regular reviews will be undertaken by a holder of a SafeWork NSW “Prepare a Work Zone Traffic Management Plan” or equivalent. Review of the CTMP shall occur monthly. All and any reviews undertaken should be documented, however key considerations regarding the review of the CTMP shall be:

- Tracking deliveries against the volumes outlined within report. Deliveries will be tracked against approved volumes and will keep a vehicle log - including Rego & time of entry - for the purpose of assessing the effectiveness of these monitoring programs.
- To identify any shortfalls and develop an updated action plan to address issues that may arise during construction (Parking and access issues)
- To ensure TGS's are updated (if necessary) by “Prepare a Work Zone Traffic Management Plan” card holders to ensure they remain consistent with the set-up on-site.

The development of a program to monitor the effectiveness of this CTMP shall be established by the Contractor. This process is expected to form part of the monitoring plan required to be included as part of the overarching Construction Environmental Management Plan (CEMP), of which this CTMP forms a part.

The roadway (including footpath) will be kept in a serviceable condition for the duration of construction. At the direction of Council, undertake remedial treatments such as patching at no cost to Council.

9.3 Work Site Inspections, Recording and Reporting

Recording and reporting of the monitoring programs shall be done in accordance within the TCAWs Manual. As such, the structure, schedule and frequency of these activities have been considered and identified.

To inspect, review and audit the temporary traffic management (TTM) arrangements implemented on site, the following actions are to be undertaken by suitably qualified personnel in accordance with TCAWS 6.1 requirements during all phases of construction, being:

- TGS Verification
- Shift / Daily
- Weekly
- Post Completion
- Portable VMS / VSLS (when required)

All inspection forms per TCAWS 6.1 Appendix E will be uploaded into the GLAASS safety system for all site inspection purposes and data retained for monitoring.

9.4 Environmental Maintenance

All works will be undertaken in accordance with the SSTOM works Site Establishment Management Plan and associated procedures and the Construction Environmental Management Plan and associated sub plans. The SSTOM works are regulated by the NSW Environment Protection Authority and works to be undertaken outside of standard construction hours will need to comply with the requirements of the Environmental Protection License (EPL).

Appendix A Swept Path Assessment



Cad File: C:\Users\WendyZheng\OneDrive - Parklife - My Documents\03_Airport Business Park\Kad\SMWSS\SMPLD-SVD-DE-TMP-00007_ABP.dwg
Plot Date: 13/07/23 - 12:18
Plot Date & Time: 100mm AT FULL SIZE

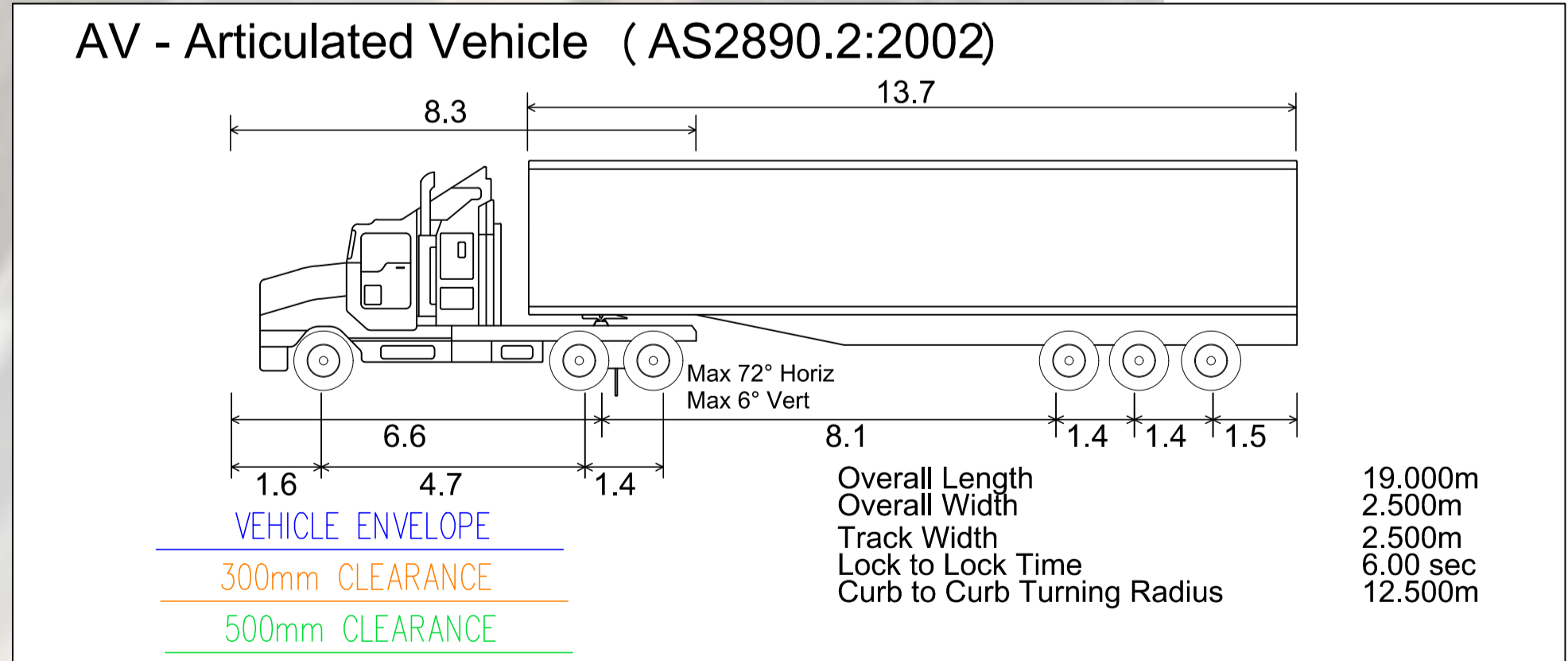

TfNSW_SecurityClassificationDesc

FOR INFORMATION

REV.	AMENDMENT DESCRIPTION	Design by	Verified by	Approved by	Date

NOTE: Do not scale from this drawing.

CLIENT:

Parklife Metro D&C

The information shown on this drawing is for the purposes of the Sydney Metro Project only. No warranty is given or implied as to its suitability for any other purpose. The Service Providers accept no liability arising from the use of this drawing and the information shown thereon for any purpose other than the Sydney Metro Project.

TAO DESIGN COMPANY/CONTRACTOR:

DRAWN	tbDrwnName	tbDrwnDate
DESIGNED	tbDsnName	tbDsnDate
DRG CHECK	tbDrgChkName	tbDrgChkDate
DESIGN CHECK	tbDsnChkName	tbDsnChkDate
APPROVED	tbApprName	tbApprDate

SYDNEY METRO - WSA - SSTOM

tbLine	tbDetail1	tbDetail2	tbDetail3
FILE No: tbFileNo	SHEET No: tbSheetNo OF Sheets ©		
STATUS: tbStatus	EDMS No: tbEDMS		
DRG No: tbAEODrNo	REV	VER	
	tRev	Ver	



100mm AT FULL SIZE Plot Date & Time: Plot Date: 13/07/23 - 14:42 Cad File: C:\Users\WendyZheng\OneDrive - Parklife - My Documents\03_Airport Business Park\caad\SMW\SSM\PLD-SVD-DE-TMP-000007_ABP.dwg

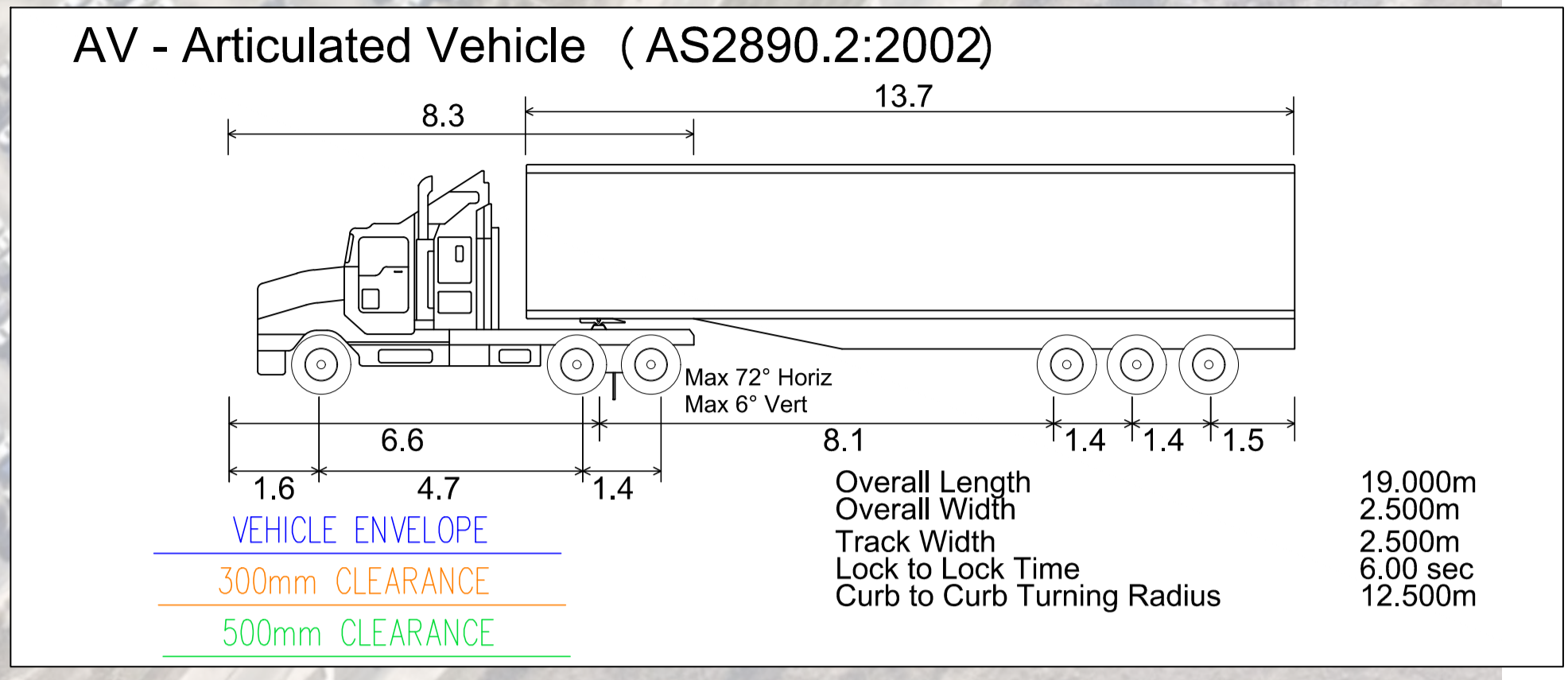
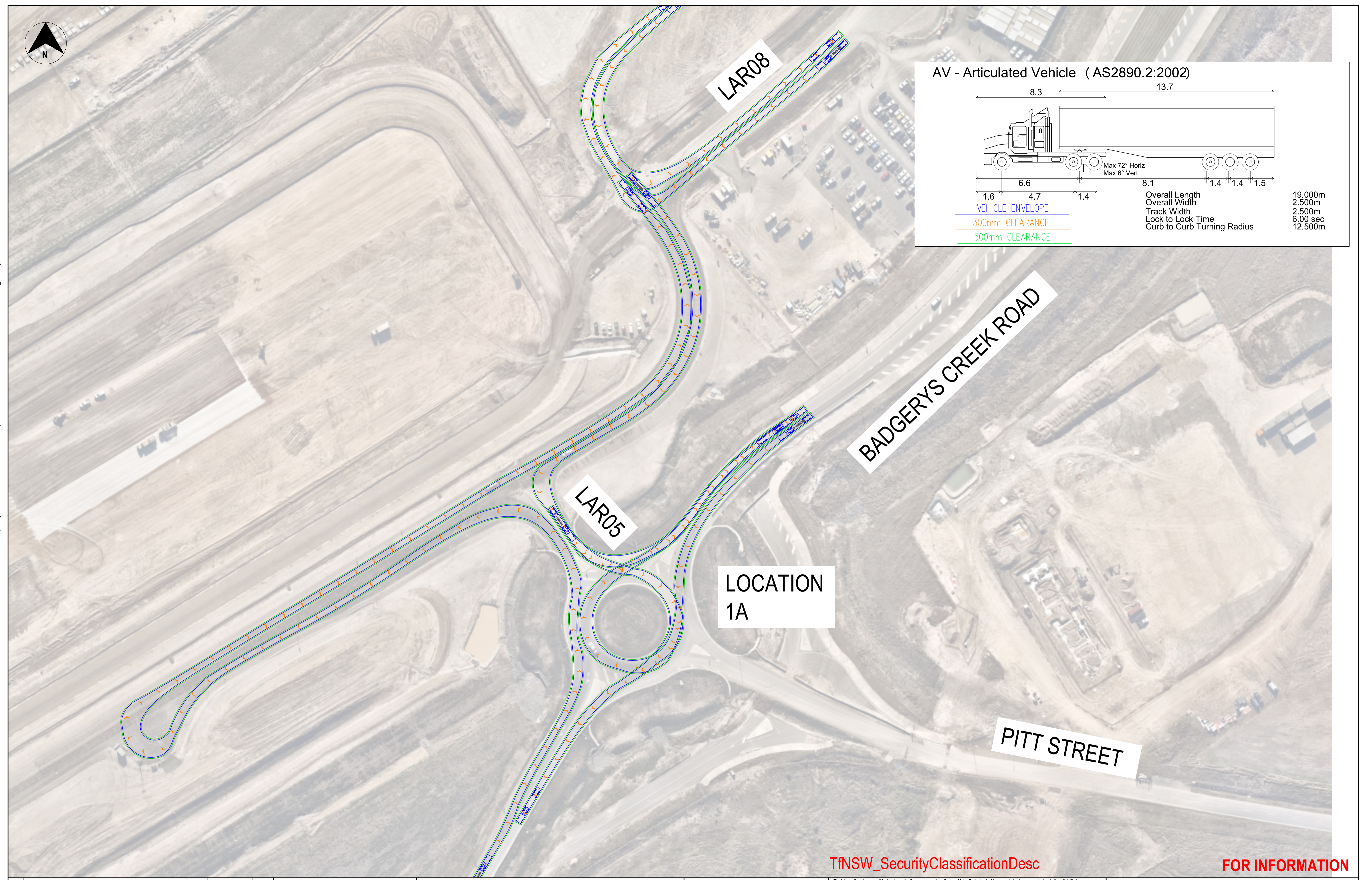

TfNSW_SecurityClassificationDesc

FOR INFORMATION

REV.	AMENDMENT DESCRIPTION	Design by	Verified by	Approved by	Date

Rev No	Rev Desc	Rev Date	Rev Scale

CLIENT:

tbAEOCompName
tbAEODisciplineDesc
tbAEOSuppName

The information shown on this drawing is for the purposes of the Sydney Metro Project only. No warranty is given or implied as to its suitability for any other purpose. The Service Providers accept no liability arising from the use of this drawing and the information shown thereon for any purpose other than the Sydney Metro Project.

TAO DESIGN COMPANY/CONTRACTOR:

DRAWN	tbDrwnName	tbDrwnDate
DESIGNED	tbDsnName	tbDsnDate
DRG CHECK	tbDrgChkName	tbDrgChkDate
DESIGN CHECK	tbDsnChkName	tbDsnChkDate
APPROVED	tbApprName	tbApprDate

tbDesignCompName
tbAEODisciplineDesc

SYDNEY METRO - WSA - SSTOM

tbLine		
tbDetail1		
tbDetail2		
tbDetail3		
FILE No:	tbFileNo	SHEET No: 15 of 15
STATUS:	tbStatus	EDMS No: tbEDMS
DRG No:	tbAEODrgNo	REV Ver

tbSheetSize Co-ordinate System: tbCoordSys Height Datum: tbHghtDat

NOTE: Do not scale from this drawing.

tbAEOCompName
tbAEODisciplineDesc
tbAEOSuppName

tbDesignCompName
tbAEODisciplineDesc

DRG No: tbAEODrgNo
REV Ver

Appendix B Risk Assessment

Sydney Metro WSA – Stabling and Maintenance Facility

Risk Assessment and Communication Tool

Site Name	Airport Business Park Station		
Site Location	Badgerys Creek Road, Badgerys Creek		
Date of Assessment	08 June 2023		
Revision	Issue I		
Document Control			
Date Issued	Revision	Issued By	Checked By
08/06/2023	Issue I	W. Zheng	D. Odobasa

Impact		Insignificant	Minor	Moderate	Major	Severe	Catastrophic
Likelihood		C6	C5	C4	C3	C2	C1
Almost certain	L1	8	19	27	29	34	36
Very Likely	L2	7	18	21	28	31	35
Likely	L3	6	11	20	23	30	33
Possible	L4	4	10	13	22	25	32
Very Unlikely	L5	3	9	12	15	24	26
Rare	L6	1	2	5	14	16	17

Risk Consequences						
	Insignificant	Minor	Moderate	Major	Severe	Catastrophic
	C6	C5	C4	C3	C2	C1
Health and Safety	Illness, first aid or injury not requiring medical treatment.	Illness or minor injuries requiring medical treatment.	Single recoverable lost time injury or illness, alternate/restricted	1-10 major injuries requiring hospitalisation and numerous days lost,	Single fatality and/or 10-20 major injuries/permanent	Multiple fatalities and/or >20 major injuries/permanent

			duties injury, or short-term occupational illness.	or medium-term occupational illness.	disabilities/chronic diseases.	disabilities/chronic diseases.
Environment	No appreciable changes to environment and/or highly localised event.	Change from normal conditions within environmental regulatory limits and environmental effects are within site boundaries.	Short-term and/or well-contained environmental effects. Minor remedial actions probably required.	Impacts external ecosystem and considerable remediation is required.	Long-term environmental impairment in neighbouring or valued ecosystems. Extensive remediation required.	Irreversible large-scale environmental impact with loss of valued ecosystems.

Likelihood		One off event (How likely?)		Repeated (How often?)
Almost certain	L1	Expected to occur frequently during time of activity or project.	> 90%	10 times or more every year
Very Likely	L2	Expected to occur occasionally during time of activity or project.	75 - 90 %	1-10 times every year
Likely	L3	More likely to occur than not occur during time of activity or project.	50 - 75 %	Once each year
Possible	L4	More likely not to occur than occur during time of activity or project.	25 - 50 %	Once every 1 to 10 years
Very Unlikely	L5	Not expected to occur during the time of activity or project.	5 - 25 %	Once every 10 to 100 years
Rare	L6	Not expected to ever occur during time of activity or project.	< 5 %	Less than once every 100 years

Risk Assessment and Communication Tool

ID. Ref	Risk and/ or Hazard	Risk Description	Location	Existing Control	Initial Risk Rating			Design Response to risk and /or hazard	Status of Risk	Assignment of risk or hazard	Residual risk rating		
					L	I	RR				C	L	RR
1	Unauthorized Access to the Site	Site prevents unauthorised access	Entire Site	Nil	L3	C2	High 28	Boundary fence will be provided as part of the main works. The design provides a defined separation between public areas and work area. Admin area is located in front of the site to minimise unauthorised visitor access	Design Solution	Main Contractor	L6	C2	Low 16
2	Interaction between pedestrians / cyclists and vehicles	Vehicles and pedestrians /cyclists to be separated as best possible	Entire Site & Access Roads	Nil	L3	C1	High 33	Dedicated footpath, pedestrian crossings and additional signage shall be provided to separate vehicles and pedestrians as best possible.	Design Solution	Main Contractor	L6	C2	Low 16
3	Potential vehicle conflict points	Vehicles can crash with each other while manoeuvring through the site	Entire Site & Access Roads	Nil	L4	C1	High 32	One-way manoeuvring around the site limits any interaction for oncoming vehicles to the access only, coupled with low speeds throughout the site. In locations	Design / Operational Solution	Main Contractor	L6	C2	Low 16

								where one-way manoeuvring is not available, all drivers will radio on ahead before entering the two way haul road section.						
--	--	--	--	--	--	--	--	--	--	--	--	--	--	--

4	Fatigue	Injury caused by fatigue	Entire Site	Nil	L3	C2	High 30	Toolbox meetings and regular breaks (in line with WHS practices) to minimise fatigue	Design Solution	Main Contractor	L6	C2	Low 16
5	Fall risks	Injury due to falls (in general)	Entire Site	Nil	L4	C1	High 32	Ensuring level changes across the site to be minimised as best possible, with additional black & yellow hazard tape/markings being installed where appropriate. Installation of handrails where level changes / ramps grades are significant.	Design Solution	Main Contractor	L6	C2	Low 16
6	Misdirected access in to neighbouring site	Vehicle in unsafe locations	Entire Site	Nil	L4	C3	Medium 22	Ensuring appropriate directional signage has been provided to ensure vehicles do not access the wrong construction site, which could create potential safety breaches and hazards for all parties	Design Solution	Main Contractor	L5	C4	Low 12
7	Conflicting Traffic Management	Coordinating Traffic Controllers could create misleading and wrong advice	Entire Site	Nil	L4	C3	Medium 22	Toolbox meetings, regular liaison with all construction teams and review of signage plans on site in order to minimise contradicting signage.	Design Solution	Main Contractor	L5	C4	Low 12

Appendix C Stakeholder Comments

NO.	DATE	COMPANY	RAISED BY	REVIEW DOC. NO.*	DOCUMENT REF*	DEED REF*	COMMENTS / RESPONSE	COMMENT CATEGORY*	LINKED ITEM NO	CLOSED OUT
01	14/06/2023	TFN	LWILBY	SMWSASSM-PLD-ABP-TF-PLN-000001	4.6.2 Truck routes	NA	The paragraph on figure 7 correctly states that no bicycle paths available along either route, however cyclists may be legally riding along the road with general traffic. Consider updating wording, and site specific awareness for drivers to reflect this.	Observation		N
	6/07/2023	PLD	WZHENG	SMWSASSM-PLD-ABP-TF-PLN-000001	4.6.2 Truck routes	NA	Drivers to site will be all licenced and be made aware of cyclists on road through the following measures: - toolbox talks - inductions - Sydney Metro Safe Heavy Vehicle Driver Introduction Programme (Appendix E) - Drivers Code of Conduct (Appendix E) - NSW Road Rules Act 2014 Section 5.2 has been updated accordingly	Observation		N
02	14/06/2023	TFN	LWILBY	SMWSASSM-PLD-ABP-TF-PLN-000001	Figure 10	NA	Figure 10 appears to show an exiting vehicle short cutting in the wrong direction through the roundabout at Pitt Street. Please update to show correct route.	Observation		N
	6/07/2023	PLD	WZHENG	SMWSASSM-PLD-ABP-TF-PLN-000001	Figure 10	NA	Figure 6 (was 10) has been updated to split the entering / exiting traffic	Observation		N
03	14/06/2023	TFN	LWILBY	SMWSASSM-PLD-ABP-TF-PLN-000001	Section 5.2 Pedestrian / Cyclist Impact Management	NA	Consider adding that there is also a wide sealed shoulder between Elizabeth Dr and Pitt St that provides greater space for cyclists and potential separation with heavy vehicles.	Observation		N
	6/07/2023	PLD	WZHENG	SMWSASSM-PLD-ABP-TF-PLN-000001	Section 5.2 Pedestrian / Cyclist Impact Management	NA	Updated in Section 5.2	Observation		N
04	14/06/2023	TFN	LWILBY	SMWSASSM-PLD-ABP-TF-PLN-000001	Appendix D Road safety audit	CTMF requirements	It appears that the road safety audit has been accidentally left off the document upload (finishes on page 31 of 39). Please upload additional pages with completed road safety audit as per the requirements in the CTMF.	Actual Non-Compliance		N
	6/07/2023	PLD	WZHENG	SMWSASSM-PLD-ABP-TF-PLN-000001	Appendix D Road safety audit	CTMF requirements	The RSA can now be found in Appendix D with the responses to it. Note there is something wrong with the page number formatting in Rev A and there was no pages 32 to 39 in Rev A. This issue has been resolved in Rev B	Actual Non-Compliance		N
05	21/06/2023	SMD	PBROGAN	SMWSASSM-PLD-ABP-TF-PLN-000001	General	CTMF	General - make clear in the document whether any aspect of the works triggers the need for referral to the local traffic committee and if so on what basis.	Observation		N
	6/07/2023	PLD	WZHENG	SMWSASSM-PLD-ABP-TF-PLN-000001	General	CTMF	Updated in Section 7.2	Observation		N
06	21/06/2023	SMD	PBROGAN	SMWSASSM-PLD-ABP-TF-PLN-000001	Section 4.6.2	CTMF & EIS approval	Section 4.6.2 - make clear in the document whether the proposed haulage/truck routes are consistent with the EIS.	Observation		N
	6/07/2023	PLD	WZHENG	SMWSASSM-PLD-ABP-TF-PLN-000001	Section 4.6.2	CTMF & EIS approval	Updated in Section 4.7.2	Observation		N
07	21/06/2023	SMD	PBROGAN	SMWSASSM-PLD-ABP-TF-PLN-000001	General	CTMF & EIS approval	General - acknowledge the Revised Env Mitigations Measures (Section 7.3 of the Submissions Report) which may apply to the works and indicate how these are being responded to.	Observation		N
	6/07/2023	PLD	WZHENG	SMWSASSM-PLD-ABP-TF-PLN-000001	General	CTMF & EIS approval	Updated in Section 5.5	Observation		N
08	22/06/2023	TFN	QMINHLA	SMWSASSM-PLD-ABP-TF-PLN-000001	4.4	N/A	BB - Plan states use of location A will be minimised as much as possible to mitigate cumulative traffic impacts. How will this be controlled?	Observation		N

NO.	DATE	COMPANY	RAISED BY	REVIEW DOC. NO.*	DOCUMENT REF*	DEED REF*	COMMENTS / RESPONSE	COMMENT CATEGORY*	LINKED ITEM NO	CLOSED OUT
	6/07/2023	PLD	WZHENG	SMWSASSM-PLD-ABP-TF-PLN-000001	4.4	N/A	Prior to handover of Access Portion 02, access to ABP site is significantly easier through Location 1F instead of Location 1A. Additionally, this will be reinforced through site inductions, toolbox talks and the Driver's Code of Conduct. Updated in Section 4.5	Observation		N
09	22/06/2023	TFN	QMINHLA	SMWSASSM-PLD-ABP-TF-PLN-000001	5.1 - Table 1	N/A	BB - Calculations in this table appear to be incorrect	Observation		N
	6/07/2023	PLD	WZHENG	SMWSASSM-PLD-ABP-TF-PLN-000001	5.1 - Table 1	N/A	Table 7 in Section 5.1 has been updated for clarity	Observation		N
10	22/06/2023	TFN	QMINHLA	SMWSASSM-PLD-ABP-TF-PLN-000001	Appendix D	N/A	BB - RSA is missing. Pages 32-39 of CTMP are missing	Observation		N
	6/07/2023	PLD	WZHENG	SMWSASSM-PLD-ABP-TF-PLN-000001	Appendix D	N/A	The RSA can now been found in Appendix D with the responses to it. Note there is something wrong with the page number formatting in Rev A and there was no pages 32 to 39 in Rev A. This issue has been resolved in Rev B	Observation		N
11	26/06/2023	SMD	PBROGAN	SMWSASSM-PLD-ABP-TF-PLN-000001	General	WSA Approval	For Alex Wilson - has this CTMP been reviewed for consistency with the WSA Airport Plan 2021 SMWSA Construction Rail Plan and SMWSA Traffic & Access CEMP ?	Observation		N
	6/07/2023	PLD	WZHENG	SMWSASSM-PLD-ABP-TF-PLN-000001	General	WSA Approval	Yes this has been reviewed against the CTMP noting the WSA Airport Plan 2021 SMWSA Construction Rail Plan (last updated 2022) and SMWSA Traffic and Access CEMP published by Metro. Refer to updated Section 1	Observation		N
12	26/06/2023	SMD	PBROGAN	SMWSASSM-PLD-ABP-TF-PLN-000001	General	WSA approval	For Alex Wilson - please note OnA construction hours under the CRP and NV CEMP and associated OOH procedure for which SM will need to provide approval.	Observation		N
	6/07/2023	PLD	WZHENG	SMWSASSM-PLD-ABP-TF-PLN-000001	General	WSA approval	OnA standard construction hours per WSA00-WSA-00400-EN-PLN-000002_NV CEMP_Rev 4 aligns with the SMWSA SSI construction hours. PLM has no plans for OOH work at the ABP site. Section 4.5 has been updated to account for the CRP and NV CEMP OOH works procedure.	Observation		N
13	26/06/2023	SMD	PBROGAN	SMWSASSM-PLD-ABP-TF-PLN-000001	Section 4.6.2	CTMF	For Alex Wilson - is PLM not expecting any trucks access to and from west of Elizabeth Drive? If yes, how will that be managed?	Observation		N
	6/07/2023	PLD	WZHENG	SMWSASSM-PLD-ABP-TF-PLN-000001	Section 4.6.2	CTMF	No PLM is not expecting any of our subcontractors / deliveries to access to and from west of Elizabeth Drive. This will be managed through our site induction, toolbox talks and drivers' code of conduct (see Appendix E). Refer also to Appendix A of the approved PLM OCTMP for the haul road routes issued to every subcontractor as part of the PLM specifications and will be distributed to all drivers again before their scheduled delivery (refer to Section 4.7.2).	Observation		N
14	26/06/2023	SMD	PBROGAN	SMWSASSM-PLD-ABP-TF-PLN-000001	Section 4.8	tba	For Alex Wilson - use "WSA Terminal Contractor" instead of "WSA Construction team"	Observation		N
	6/07/2023	PLD	WZHENG	SMWSASSM-PLD-ABP-TF-PLN-000001	Section 4.8	tba	updated in Section 4.4 for wording	Observation		N
15	26/06/2023	SMD	PBROGAN	SMWSASSM-PLD-ABP-TF-PLN-000001	Section 4.8	tba	For Alex Wilson - is the plan for the batch plant to feed AEC? If so, this will need to be reviewed for any additional traffic impact on Badgerys Creek Rd and review consistency with the SMWSA T&A CEMP.	Observation		N

NO.	DATE	COMPANY	RAISED BY	REVIEW DOC. NO.*	DOCUMENT REF*	DEED REF*	COMMENTS / RESPONSE	COMMENT CATEGORY*	LINKED ITEM NO	CLOSED OUT
	6/07/2023	PLD	WZHENG	SMWSASSM-PLD-ABP-TF-PLN-000001	Section 4.8	tba	Yes the temporary concrete batching plant will feed AEC, see updated Section 4.4. Refer to updated Section 4.7.1 for the project truck vehicle volumes generated out of ABP inclusive of the concrete batching plant volumes for AEC and updated Section 5.1 for review and consistency with SMWSA Traffic and Access CEMP.	Observation		N
16	26/06/2023	SMD	PBROGAN	SMWSASSM-PLD-ABP-TF-PLN-000001	Section 4.8	tba	For Alex Wilson - entry and exit location for the batch plant into the shared road within Portion 6 is not clear. Potential high risk location for traffic collision within the site. Risk mitigation of vehicle collision as well as personnel struck by vehicle to be considered.	Observation		N
	6/07/2023	PLD	WZHENG	SMWSASSM-PLD-ABP-TF-PLN-000001	Section 4.8	tba	Concrete batching plant design and internal traffic management details will be submitted as part of SSTOM BAN 02 as PLM is still in the process of procuring the concrete batching plant.	Observation		N
17	26/06/2023	SMD	PBROGAN	SMWSASSM-PLD-ABP-TF-PLN-000001	Section 5.1	tba	For Alex Wilson - has the volume of concrete trucks movement from Batch plant been accounted for in this table?	Observation		N
	6/07/2023	PLD	WZHENG	SMWSASSM-PLD-ABP-TF-PLN-000001	Section 5.1	tba	yes	Observation		N
18	26/06/2023	SMD	PBROGAN	SMWSASSM-PLD-ABP-TF-PLN-000001	Table 7	CTMF	For Alex Wilson - Table 7 - what is the total volume including FIW contractors ?	Observation		N
	6/07/2023	PLD	WZHENG	SMWSASSM-PLD-ABP-TF-PLN-000001	Table 7	CTMF	The total volume generated by all contractors within the SMWSA project will be in accordance to the maximum traffic volumes identified in Environmental Impact Statement (EIS) of Sydney Metro Western Sydney Airport – Technical Paper 1 - Transport Mitigation Measures Section 4.1.1	Observation		N
19	26/06/2023	SMD	PBROGAN	SMWSASSM-PLD-ABP-TF-PLN-000001	General	contract notice	For Alex Wilson - as advised via Contract Notice, PLM will become the owners of this Access Road in 2025	Observation		N
	6/07/2023	PLD	WZHENG	SMWSASSM-PLD-ABP-TF-PLN-000001	General	contract notice	Yes PLM will take responsibility of LAR08 as the owners in 2025 once AWJV leaves this access road	Observation		N
20	26/06/2023	SMD	PBROGAN	SMWSASSM-PLD-ABP-TF-PLN-000001	Section 5.5	CTMF	For Alex Wilson - how will PLM D&C ensure vehicle generation numbers be within identified limits in EIS? Will this be by monitoring/ongoing study of traffic volume ?	Observation		N
	6/07/2023	PLD	WZHENG	SMWSASSM-PLD-ABP-TF-PLN-000001	Section 5.5	CTMF	All vehicular access to the ABP site will be registered a week in advance on the PLM logistics software to apply for a loading slot and a time or a parking space. The site superintendent will manage the applications to ensure vehicle generation numbers stay within the identified limits in the EIS. The same software will retain the vehicle data per SSI condition E108. See updated Section 5.5.	Observation		N
21	26/06/2023	SMD	PBROGAN	SMWSASSM-PLD-ABP-TF-PLN-000001	Section 8	tba	For Alex Wilson - please review the SMWSA Community & Stakeholder Engagement Plan to review notification requirement for OnA.	Observation		N
	6/07/2023	PLD	WZHENG	SMWSASSM-PLD-ABP-TF-PLN-000001	Section 8	tba	Section 8 has been reviewed by the PLM community team found to be consistent with the SMWSA Community and Stakeholder Engagement Plan.	Observation		N
22	26/06/2023	SMD	PBROGAN	SMWSASSM-PLD-ABP-TF-PLN-000001	Section 9.1	CTMF	For Alex Wilson - there is no Road Safety Audit attached.	Observation		N
	6/07/2023	PLD	WZHENG	SMWSASSM-PLD-ABP-TF-PLN-000001	Section 9.1	CTMF	The RSA can now been found in Appendix E with the responses to it.	Observation		N

NO.	DATE	COMPANY	RAISED BY	REVIEW DOC. NO.*	DOCUMENT REF*	DEED REF*	COMMENTS / RESPONSE	COMMENT CATEGORY*	LINKED ITEM NO	CLOSED OUT
23	26/06/2023	SMD	PBROGAN	SMWSASSM-PLD-ABP-TF-PLN-000001	Appendix B	CTMF	For Alex Wilson - one way manoeuvring may not be possible esp. for the 1st handover of Portion 6 at ABP. What other controls will be in place to manage this risk ?	Observation		N
	6/07/2023	PLD	WZHENG	SMWSASSM-PLD-ABP-TF-PLN-000001	Appendix B	CTMF	Updated in Appendix B, Risk Assessment Table Ref 3	Observation		N
24	26/06/2023	TFN	JHODDER	SMWSASSM-PLD-ABP-TF-PLN-000001	1 & 2	NA	Page 9 and 11 mentions the CTMP will be updated for Access Portions 2 and 3. A new (separate) CTMP and/or addendum should be issued for each portion to reduce confusion. Any approval provided at this stage by CJP would be for Access Portion 1 only.	Observation		N
	6/07/2023	PLD	WZHENG	SMWSASSM-PLD-ABP-TF-PLN-000001	1 & 2	NA	PLM is aware and will be updating this CTMP accordingly for access portion handovers. Refer to updated Section 1.	Observation		N
25	26/06/2023	TFN	JHODDER	SMWSASSM-PLD-ABP-TF-PLN-000001	3.4.1	NA	The following website provides access to some traffic volume data which may assist in understanding the surrounding road network; https://scatter.aai.transport.nsw.gov.au/scatter_map	Observation		N
	6/07/2023	PLD	WZHENG	SMWSASSM-PLD-ABP-TF-PLN-000001	3.4.1	NA	I have tried to access the scatter.aai website and I can not get access to it.	Observation		N
26	26/06/2023	TFN	JHODDER	SMWSASSM-PLD-ABP-TF-PLN-000001	3.4.2	NA	Crash map does not have a legend, nor is it very clear.	Observation		N
	6/07/2023	PLD	WZHENG	SMWSASSM-PLD-ABP-TF-PLN-000001	3.4.2	NA	Crash map in Figure 2 is now updated with a legend and re-sized for clarity.	Observation		N
27	26/06/2023	TFN	JHODDER	SMWSASSM-PLD-ABP-TF-PLN-000001	3.4.3	NA	TMP mentions that vulnerable road users (VRUs) need to be addressed in the CTMP. However, there is nothing in the CTMP showing how the project intends to address/mitigate these risks.	Observation		N
	6/07/2023	PLD	WZHENG	SMWSASSM-PLD-ABP-TF-PLN-000001	3.4.3	NA	See updated Section 5.2 and the site specific Driver's Code of Conduct in Appendix E.	Observation		N
28	26/06/2023	TFN	FLARUE	SMWSASSM-PLD-ABP-TF-PLN-000001	3.4.3	NA	Is the description of The Northern Road correct for the footpath location?	Observation		N
	6/07/2023	PLD	WZHENG	SMWSASSM-PLD-ABP-TF-PLN-000001	3.4.3	NA	Following a site visit to The Northern Road on 29/06/23, footage was taken of the drive between The Great Western Highway and Bringelly Road in both direction. Table 5 in Section 3.4.3 has been updated following analysis of footage.	Observation		N
29	26/06/2023	TFN	FPASSARELL	SMWSASSM-PLD-ABP-TF-PLN-000001	3.4.3 & 5.3	NA	Section 3.4.3 (Table 5) and 5.3 indicate that no buses traverse Badgerys Creek Rd or Elizabeth Dr which is incorrect. These sections should be updated with the following information: Badgerys Creek Rd – •Route 801 uses this roadway North of Pitt St •Routes 1014, 2017 & 2053 (school services) uses this roadway south of Longleys Rd Elizabeth Drive – •Routes 4147, 4510, 801, 9057, 9615, 9616 traverse this section of roadway	Observation		N
	6/07/2023	PLD	WZHENG	SMWSASSM-PLD-ABP-TF-PLN-000001	3.4.3 & 5.3	NA	Sections 3.4.3 and 5.3 updated to address the bus routes on Elizabeth Drive and Badgerys Creek Road	Observation		N
30	26/06/2023	TFN	FLARUE	SMWSASSM-PLD-ABP-TF-PLN-000001	4.6	NA	Are the daily truck volumes presented in line with the EIS requirements? If they are not a more extensive traffic assessment will be required to understand the impact to the surrounding road network.	Observation		N
	6/07/2023	PLD	WZHENG	SMWSASSM-PLD-ABP-TF-PLN-000001	4.6	NA	Refer to Section 5.1 for the breakdown of traffic volume and impact mitigation. Section 4.7 (formerly 4.6) has also been updated for the latest projected traffic volumes from the construction team	Observation		N
31	26/06/2023	TFN	JHODDER	SMWSASSM-PLD-ABP-TF-PLN-000001	5.2	NA	Is a traffic controller required to manage pedestrians at this intersection?	Observation		N

Wendy Zheng

From: Wendy Zheng
Sent: Friday, 7 July 2023 9:46 AM
To: Wendy Zheng
Subject: FW: CTMP Review Tracking for WSA Metro - SSTOM Contract

OFFICIAL

From: Stella Qu <QuS@liverpool.nsw.gov.au>
Sent: Tuesday, 27 June 2023 3:35 PM
To: Berin Gordon <Berin.Gordon@transport.nsw.gov.au>
Cc: Charles Wiafe <wiafec@liverpool.nsw.gov.au>; Riham Gergis <GergisR@liverpool.nsw.gov.au>
Subject: RE: CTMP Review Tracking for WSA Metro - SSTOM Contract

CAUTION: This email is sent from an external source. Do not click any links or open attachments unless you recognise the sender and know the content is safe.

Hi Berin,

Please find Council's comments on the CTMP for the airport business park station as follows:

- All construction vehicles shall be via the approved haulage routes as part of the Environmental Impact Statement (EIS) approval. Due to increasing construction traffic volumes along Mamre Road and Elizabeth Drive, it is recommended that all heavy vehicles to the subject site be via the M4 Motorway and The Northern Road.
- A Driver Code of Conduct should be included in the CTMP. The drivers should use the approved haulage routes and designated on-site parking area.
- A notice with contact phone number and email details for community to make contacts regarding work activities are to be installed at the site.
- Parking for all construction workers should be accommodated within the development site. On-site heavy vehicle parking area is to be provided with delineation and signage.
- A copy of road safety audit (RSA) report is to be submitted to Council for review prior to the commencement of construction.

Let me know if you have any questions.

Regards,

Stella Qu
Transport Planner



We acknowledge the traditional custodians of the land that now resides within Liverpool City Council's boundaries, the Darug and Dharawal nations.

This email (including any attachments) may contain confidential and/or legally privileged information. If you are not the intended recipient please delete this email and notify us if you are prohibited.

From: Berin Gordon <Berin.Gordon@transport.nsw.gov.au>
Sent: Tuesday, June 13, 2023 10:05 AM
To: Francois La Rue <Francois.LaRue@transport.nsw.gov.au>; Justine Hodder <Justine.Hodder@transport.nsw.gov.au>; Quac minh La <QuacMinh.LA@transport.nsw.gov.au>; Luke Wilby <Luke.Wilby@transport.nsw.gov.au>; Michael Holmes <Michael.Holmes@transport.nsw.gov.au>; Lauren Vallejo <Lauren.Vallejo@penrith.city>; Stella Qu <QuS@liverpool.nsw.gov.au>; Riham Gergis <GergisR@liverpool.nsw.gov.au>
Cc: Frankie Passarelli <Frankie.PASSARELLI@transport.nsw.gov.au>; Md Mahbubur Rahman <Mahbubur.Rahman2@transport.nsw.gov.au>; Charles Wiafe <WiafeC@liverpool.nsw.gov.au>; Thomas Ng <Thomas.Ng@transport.nsw.gov.au>; Maria Felarca <Maria.Felarca3@transport.nsw.gov.au>; Lindsay Baker <Lindsay.Baker2@transport.nsw.gov.au>; Biswajit Paul <Biswajit.Paul@transport.nsw.gov.au>; Philip Brogan <Philip.Brogan@transport.nsw.gov.au>; Emlyn Gray <Emlyn.Gray3@transport.nsw.gov.au>; Daniel Dixon <Daniel.Dixon@transport.nsw.gov.au>; Maryam Abparvar <Maryam.Abparvar@transport.nsw.gov.au>; Kelly Yoon <Kelly.Yoon@transport.nsw.gov.au>; Tim Dewey <Tim.Dewey@transport.nsw.gov.au>
Subject: CTMP Review Tracking for WSA Metro - SSTOM Contract

Morning

Phil Brogan is on leave until Thursday.

- The *Airport Business Park CTMP* has been released for **review**
- The *Orchard Hills CTMP* is under **review** by stakeholders
- The *Overarching CTMP* has been submitted for **approval**

Tracking table updated below.

Thank you to those who promptly comment and/or close their comments/reviews.

Any issues please call me, a chat always provides clarity. My details at the bottom.

Cheers

		<p style="text-align: center;">IQ #IRU#UHYIHZ #z lk#FMS/#S) S#Frxfib#P hwr,</p>					<p>Vdnhkr@hu# Whdp e.lghu# frp p hqw# vwdkcv</p>	
Orfdwirg	Grfxp hqw	Gdwh#Vnqw -iurp #P hwr,	Whdp e.lghu#Uhl	Gd #	Gd #	Gd #3 -FRE,		Gdwh#Vnqw -iurp #P hwr,

DOO	R FWP S	3 8 2 3 8 2 5 6	VP Z VDVVP OVP G 0 W[0333;5;	3 ; 23 8 2 5 6	4 9 2 3 8 2 5 6	4 < 23 8 2 5 6	Z lk# vdnhkrqghu# iru#issurydo	3 < 23 9 2 5 6	VP
RUFKDUG# KIDOV	FWP S	3 9 2 3 9 2 5 6	VP Z VDVVP OVP G 0 W[034554	3 : 23 9 2 5 6	4 9 2 3 9 2 5 6	5 4 2 3 9 2 5 6	Z lk# vdnhkrqghu# iru#hyhz	#	
DIJSRUW# EXVIQHVV# DSUN	FWP S	4 6 2 3 9 2 5 6	VP Z VDVVP OVP G 0 W[0345:4	4 6 2 3 9 2 5 6	4 < 23 9 2 5 4	5 9 2 3 9 2 5 6	Z lk# vdnhkrqghu# Iru#hyhz	#	

Iru#krv#kvlgj#vhp e lghu#Gdvkerdug#rx#z l#lqg#kh#frp p hq#v#vwrq#lq#kh#z lgrz #vng#z runirz #k#l#z lgrz #p d/#h#Erwsvng#
#arvng #lqg#htxlnh{s dqg lqj #

Iru#krv#kdw#vnh#kh#p d d qn#rx#z l#h#vnhq#wuljkw#r#kh#p dlq#s dj h#r #kh#frp p hq#v#vwrq#f d f n#r q#kh#l n g#h q f l#l q g#s d s h u#
l r q #l h y l z #l q g#f r p p h q w#f k h f n#e r { #l q g#D Y H, #G r q #i r u j h w#r #l n w u g#r #k h#p d l q#s d j h#r #f a r v h#x w#f k h f n#k h#e r { #k h#z k r d#h y l z #
v h v l r q#l q g#D Y H#D#g r w h#g r#g r w#r#k l#w h s#i#l q g#l r q d#f r p p h q w#p d/#h#r q#k h#z d/#z d l w#q w d#h#v#f h u d l y#g r#x u k h#f r p p h q w#z l#h
p d g h#k h q#f a r v h#x w#f k h f n#k h#e r { #k h#z k r d#h y l z #h v v l r q#l q g#D Y H.

Berin Gordon
Transport & Logistics Manager
Sydney Metro
M 0438 490 466

sydneymetro.info
Level 43, 680 George Street, Sydney NSW 2000
PO Box K659, Haymarket NSW 1240



This email is intended only for the addressee and may contain confidential information. If you receive this email in error please delete it and any attachments and notify the sender immediately by reply email. Transport for NSW takes all care to ensure that attachments are free from viruses or other defects. Transport for NSW assume no liability for any loss, damage or other consequences which may arise from opening or using an attachment.

Consider the environment. Please don't print this e-mail unless really necessary.

Disclaimer

This email has been scanned for viruses and malware, and may have been automatically archived by **Mimecast Ltd**, on behalf of **Liverpool City Council**.

This email is intended only for the addressee and may contain confidential information. If you receive this email in error please delete it and any attachments and notify the sender immediately by reply email. Transport for NSW takes all care to ensure that attachments are free from viruses or

other defects. Transport for NSW assume no liability for any loss, damage or other consequences which may arise from opening or using an attachment.

 **Consider the environment. Please don't print this e-mail unless really necessary.**

Appendix D Road Safety Audit

Traffic Management Road Safety Audit Report

Sydney Metro – Western Sydney Airport

Airport Business Park Station – Access Portion 01

Project Number 220751

Draft Report 4/07/2023

Client Parklife Metro

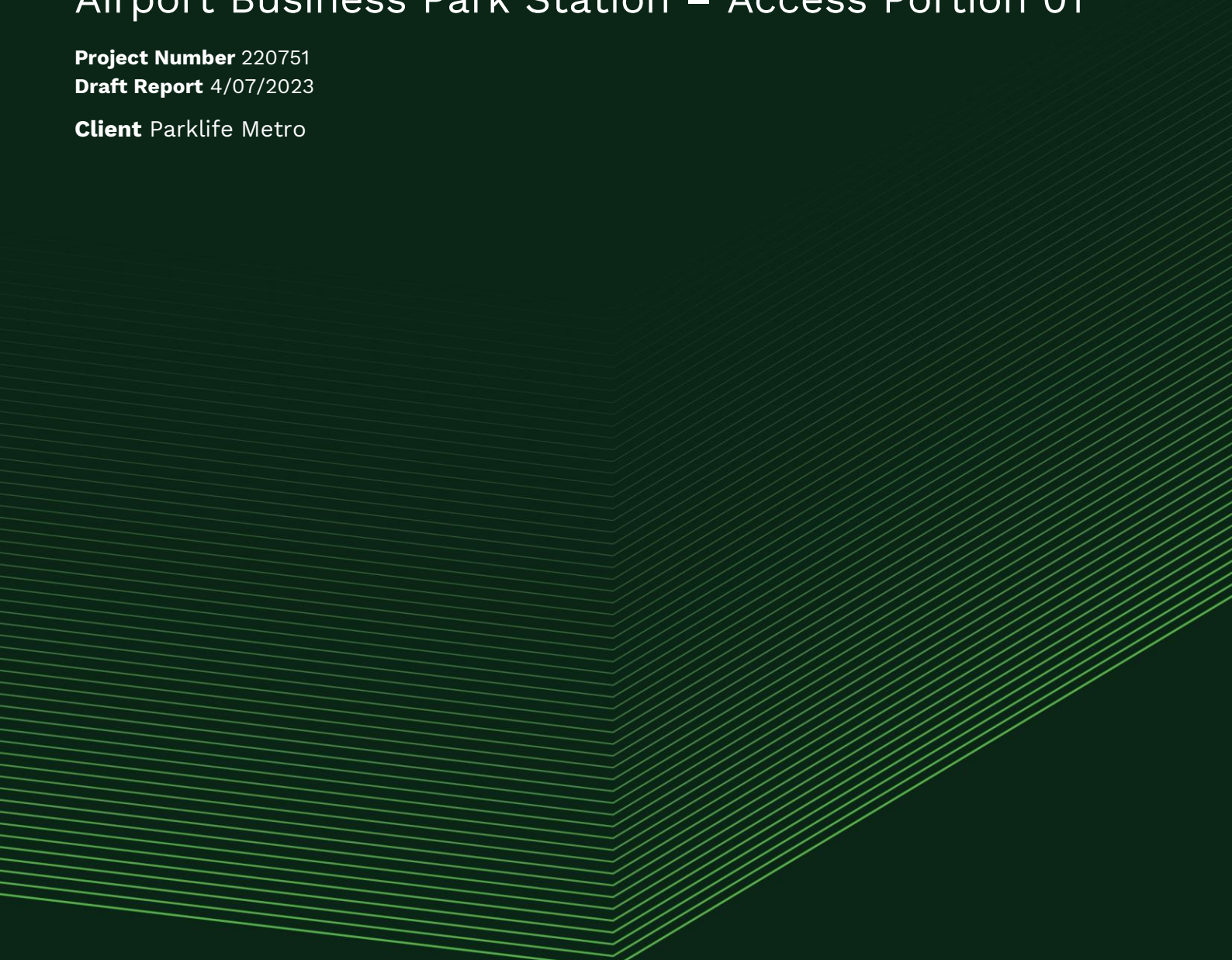

Document control record

Document prepared by:

Trafficworks Pty Ltd

ABN 59 125 488 977

1st Floor 132 Upper Heidelberg Rd Ivanhoe Vic 3079

PO Box 417 Ivanhoe Vic 3079

Ph (03) 9490 5900

www.trafficworks.com.au

Disclaimer

The information contained in this document is intended to be received, used and relied upon by the named addressee or client only for the purpose for which it has been prepared. Trafficworks Pty Ltd does not warrant the accuracy or relevance of the information, including by implication, contained in this document if it is used or relied upon by any person other than the named addressee or client. Copying, reproduction including by electronic means, unauthorised use or disclosure of this document is prohibited except with the express written authorisation of Trafficworks Pty Ltd.

Document control

Report title	Sydney Metro – Western Sydney Airport Airport Business Park – Access Portion 01
--------------	--

Project number	220751
----------------	--------

Client	Parklife Metro
--------	----------------

Client contact	Wendy Zheng (0401 969 768)
----------------	----------------------------

Revision	Date issued	Revision details / status	Prepared by	Authorised by
Draft	4/07/2023	Preliminary draft	Bernard Chan	Paul Mihailidis

Table of Contents

1	Introduction	1
2	Road safety audit (RSA) overview	3
2.1	Audit team	3
2.2	Commencement meeting	3
2.3	Inspection.....	3
2.4	Risk ratings	3
2.5	Safe System approach.....	5
2.6	Supporting information used in the audit.....	5
3	Site Description.....	6
3.1	Existing conditions	6
3.2	Proposed conditions.....	7
4	Findings	8
5	Conclusion.....	15
	Appendix 1 – Severity guidance sheet.....	16
	Appendix 2 – Likelihood / severity risk matrix.....	17

1 Introduction

The Sydney Metro – Western Sydney Airport project involves the construction and operation of a 23 km new metro rail line between St Marys to the north and the Western Sydney Airport Aerotropolis to the south.



Figure 1: Overview of Sydney Metro – Sydney Airport project

Parklife Metro engaged Trafficworks to undertake a road safety audit (RSA) of the Construction Traffic Management Plan (CTMP) prepared for the Airport Business Park (ABP) Station.

Access to the site will be handed over to SSTOM (Parklife Metro) in three stages:

- Access portion 01: August 2023
- Access portion 02: May 2024
- Access portion 03: July 2024.

The focus of this RSA will be for Access Portion 01. The CTMP will be updated with details of Access Portion 02 and 03 traffic management and will be subject to a separate RSA at a later date.

We conducted this RSA in line with the procedures set out in the Austroads Guide to Road Safety Part 6: Road Safety Audits (2022). For more information, see section 2, Road Safety Audit (RSA) overview.

Both the site and the supporting documentation were reviewed to identify issues that impact road user safety – for more information, see section:

- section 2.6, Supporting information used in the audit
- section 3, Site Description.

Our findings are presented in section 4.

Note that the auditor cannot guarantee that every issue that impacts road user safety has been identified.

2 Road safety audit (RSA) overview

2.1 Audit team

The audit was conducted by:

Paul Mihailidis [BEng (Civil), GradCert Mgt, MIEAust, CPEng, NER]

RSA-03-0796 – Level 3 road safety auditor (lead auditor)

and

Bernard Chan [BEng(Civil)(Hons), CPEng, NER]

RSA-03-1649 – Level 3 road safety auditor (team member)

2.2 Commencement meeting

A commencement meeting was held at the Parklife offices on the morning of Thursday 29 June 2023.

2.3 Inspection

The audit included an inspection of the site during the:

- Afternoon of 29/06/2023

The audited sections were driven along in each direction. Video footage was captured and has been referenced in the audit findings.

The conditions during the daytime inspection were fine and sunny.

2.4 Risk ratings

The findings of this audit have been assigned a risk rating based on the likelihood of a crash occurring, together with the potential severity of that crash. For more information about:

- crash severity – see Appendix 1
- the likelihood/severity risk matrix, see Appendix 2.

The risk ratings adopted for this audit are as follows:

- Extreme – must be corrected regardless of cost
- High – should be corrected or the risk significantly reduced, even if the treatment cost is high

- Medium – should be corrected or the risk significantly reduced, if the treatment cost is moderate, but not high
- Low – should be corrected or the risk reduced if the treatment cost is low
- Negligible – no action required.

Trafficworks also denotes a risk rating of ‘Note only’ for:

- drafting errors, omissions and issues that are outside the scope of works
- items within the scope of works that do not represent a road safety risk.

2.5 Safe System approach

Transport for NSW and Austroads have formally adopted the Safe System approach. The basic principles of the Safe System approach are:

- Humans are fallible, and will inevitably make mistakes when driving, riding, or walking.
- Despite this, road trauma should not be accepted as inevitable. No one should be killed or seriously injured on our roads.
- To prevent serious trauma, the road system must be forgiving, so that the forces of collisions do not exceed the limits that the human body can tolerate.

Therefore, as far as is practically possible, infrastructure should be designed, and travel speeds managed, so that crash impact speeds are below the thresholds outlined in Appendixes 1 and 2.

Each road safety issue has been assessed based on:

- its kinetic energy transfer
- the likelihood of a serious injury or fatality occurring assessed against the thresholds outlined in Appendixes 1 and 2.

2.6 Supporting information used in the audit

The following document was used when conducting the audit:

- Airport Business Park Station – Construction Traffic Management Plan, prepared by Parklife Metro D&C. Document no. SMWSASSM-PLD-ABP-TF-PLN-000001, Rev A, dated 08/06/2023

3 Site Description

3.1 Existing conditions

The site is located within the Western Sydney Airport site, with access via Badgerys Creek Road.

Badgerys Creek Road, between Elizabeth Drive to Pitt Street, is a duplicated road comprising two traffic lanes in each direction separated by a wide central median. It has a posted speed limit of 60 km/h.

Two access points have been created via Badgerys Creek Road to the ABP Station site:

- Access Location 1A (roundabout at the intersection of Badgerys Creek Road and Pitt Street)
- Access Location 1F (left in / left-out only access road to the north of Pitt Street).

The access points connect onto a network of internal roads within the Western Sydney Airport site.

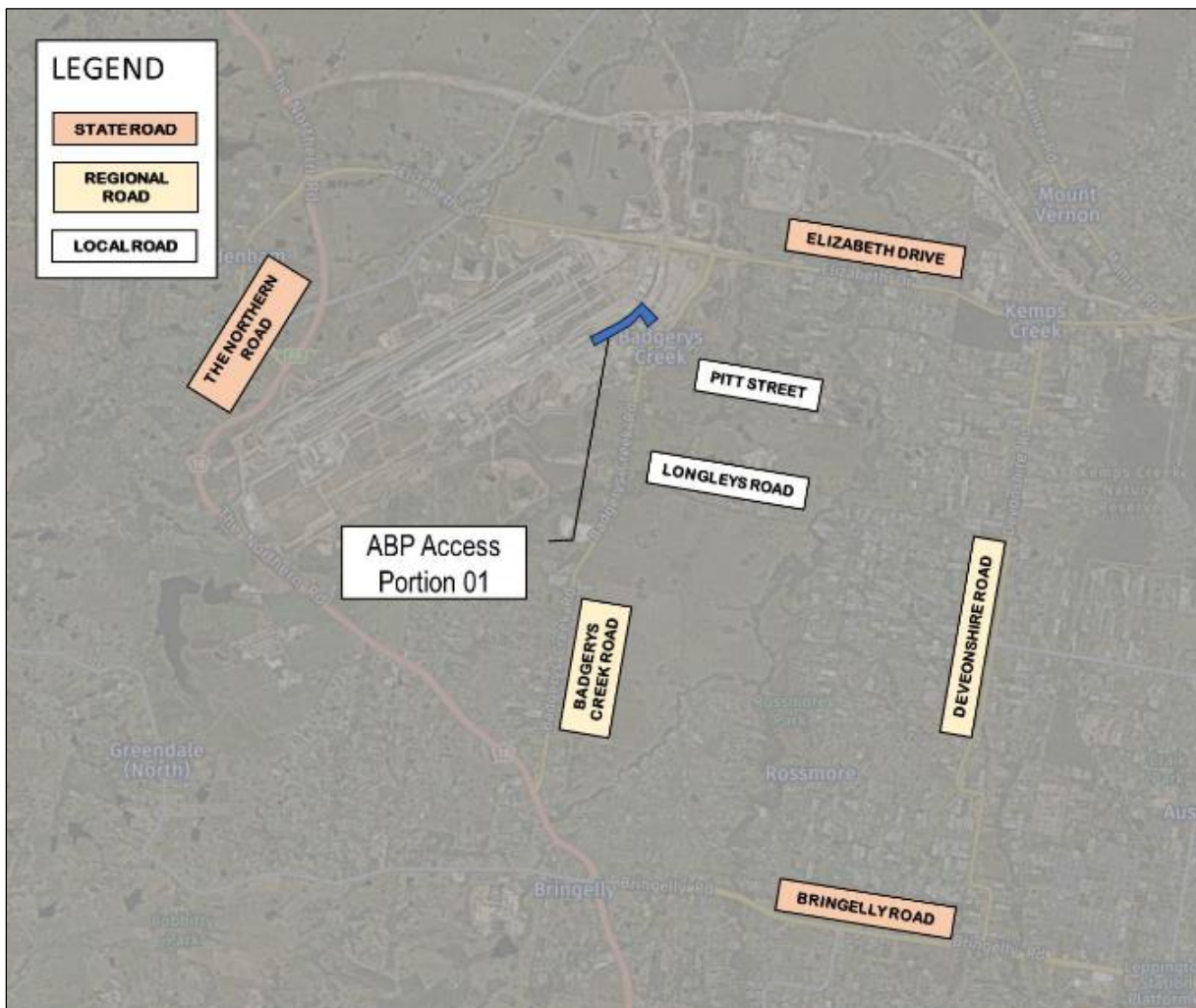

Figure 2: Site location

3.2 Proposed conditions

Access Portion 01 will be handed over to SSTOM on 11 August 2023. The CTMP details the following traffic management arrangements after the handover of Access Portion 01 to SSTOM:

- vehicle access will be from Badgerys Creek Road, from either Location 1A or Location 1F. The CTMP indicates measures will be taken to minimise the use of Location 1A as much as possible
- the largest truck required for ABP construction will be the 25 m long Articulated Vehicle (25 m AV)
- internal vehicle access will follow the sub-Shared Access Road Protocol (sub-SARP) established for each of the internal access roads within the airport site
- all vehicles that access from Location 1A will be required to turn left to go south and use the P-turn to go north
- no additional traffic control is proposed at either access locations
- the access arrangements within the Access Portion 01 has not been detailed within the CTMP and therefore could not be assessed in this audit
- a Traffic Guidance Scheme (TGS) has not been detailed in the CTMP at the time of this audit, and therefore could not be assessed.

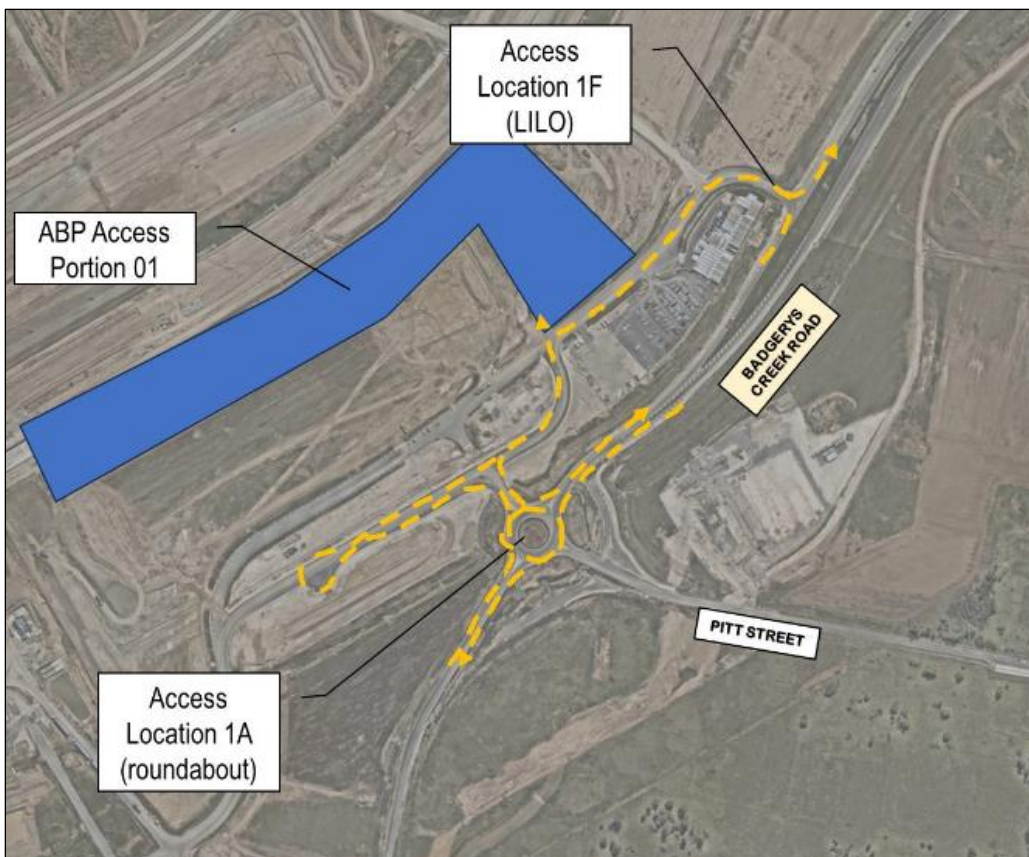

Figure 3: Proposed site access arrangements – Access Portion 01

4 Findings

Table 1 outlines the findings of this audit, noting the columns to the right of the table will be completed by the client after receiving and reviewing this report.

RSAs are a formal process and the client is required to respond to the audit's findings in writing. A client is under no obligation to accept all of the audit findings and should consider these in conjunction with all other project considerations. If the client does not accept the findings, then reasons should be included within the written response.

It is not the role of the auditor to approve the client's response to the audit.

5 Conclusion

This Road Safety Audit has been conducted in accordance with the procedures set out in the *Austrroads Guide to Road Safety Part 6: Road Safety Audits (2022)*.

The site was inspected and supporting documentation examined.

The findings presented in the previous section of this document are provided for consideration by the client and any other interested parties.

Auditors



Tuesday, 4 July 2023

Paul Mihailidis [BEng (Civil), GradCert Mgt, MIEAust, CPEng, NER]

RSA-03-0796 – Level 3 road safety auditor (lead auditor)



Tuesday, 4 July 2023

Bernard Chan [BEng(Civil)(Hons), CPEng, NER]

RSA-03-1649 – Level 3 road safety auditor (team member)

Table 1: Audit findings

No	Audit findings	Photos	Risk rating	Client response	
				Accept: Yes/No	Reasons/ Comments
1 General issues					
1.1.	<p>Chevron pavement markings have been installed in the left turn lane at Access 1F.</p> <p>This can cause confusion on whether the lane can be used/accessed.</p> <p>Motorists may hesitate and brake on Badgerys Creek Road, resulting in rear end crashes.</p>		<p>Likelihood: Unlikely</p> <p>Severity: Minor</p> <p>Risk rating: LOW</p>	Yes	<p>Liaise with TCWG to determine original reason for the chevron marking, and if appropriate, the party responsible for removal of chevron marking.</p>

No	Audit findings	Photos	Risk rating	Client response	
				Accept: Yes/No	Reasons/ Comments

1.2. Linemarking is faded within the internal roads.
This could lead to trucks crossing the centreline, resulting in a head-on crash



Likelihood: Rare
Severity: Minor
Risk rating: **NEGLIGIBLE**

Yes
Liaise with TCWG to determine which contractor is responsible for repainting linemarking within internal roads.

No	Audit findings	Photos	Risk rating	Client response
----	----------------	--------	-------------	-----------------

1.3. The swept path shows the 25 m articulated vehicle turning left in and out from the through lane at access 1F.

The snake channelisers have been installed between the turn lane and the through lane.

This restricts movements and may cause confusion for motorists, resulting in a minor crash.

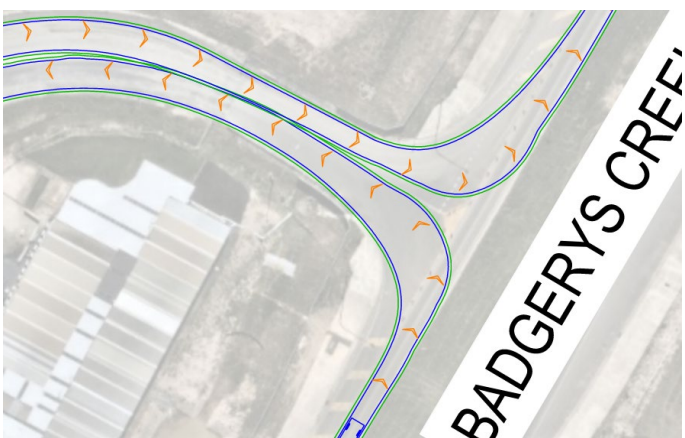

Likelihood: Possible
 Severity: Insignificant
 Risk rating: **LOW**

Yes

Swept path assessment revised with 19m AV on newer aerial image base. No additional traffic management devices are required.

Recommendation has been given to TfNSW to provide additional warning signs on approach to the left turn lane.

No Audit findings	Photos	Risk rating	Client response	
			Accept: Yes/No	Reasons/ Comments

1.4. The swept paths indicate that heavy vehicles must turn left in from the through lane at access 1F.

Light vehicles may attempt to enter the left turn lane whilst a heavy vehicle is turning left in from the adjacent through traffic lane.

This may result in a side swipe crash.

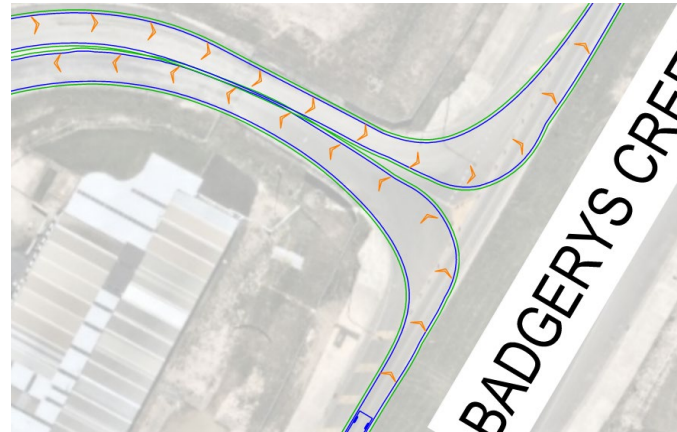

Likelihood:
Rare

Severity:
Serious

Risk rating:
MEDIUM

Yes

Revised swept path with 19m AV show HV can turn left from left lane at access 1F. LVs will queue behind HVs and vice versa.

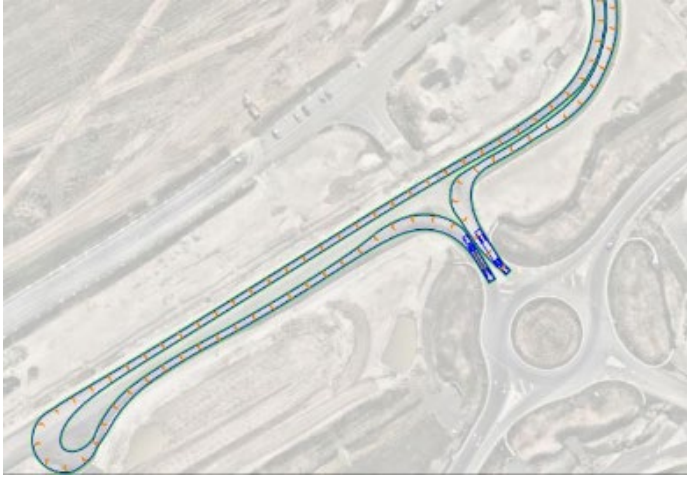
No	Audit findings	Photos	Risk rating	Client response	
				Accept: Yes/No	Reasons/ Comments
1.5.	<p>The CTMP and swept paths indicate that all vehicles entering from access 1A are required to turn left only to travel south and use the p-turn to head north.</p> <p>There is nothing in the CTMP detailing the measures that will be implemented to enforce this movement (e.g. signage, linemarking, traffic controller). As this is not a typical movement, vehicles may ignore this protocol if adequate controls are not in place.</p> <p>This can lead to conflicting movements or a risk of queuing through the roundabout, resulting in a crash.</p>		<p>Likelihood: Unlikely</p> <p>Severity: Minor</p> <p>Risk rating: LOW</p>	Yes	<p>Recommendation for additional signage and linemarking requirements to reinforce the left turn movement has been submitted to AWJV for implementation.</p>

No Audit findings	Photos	Risk rating	Client response	
			Accept: Yes/No	Reasons/Comments
<p>1.6. A B-double was observed reversing during the inspection, having entered the wrong access allocated for light vehicles only.</p> <p>This occurred within the airport site outside the scope of this audit, however, it is noted this issue could occur again if adequate wayfinding and traffic control is not provided.</p>		NOTE ONLY	Yes	<p>Will review communications protocols and ensure all drivers approaching the site are aware of site access locations and direction of traffic flow.</p>

Client response completed by:

Name: _____

Signed: _____ Date: _____

Appendix 1 – Severity guidance sheet

Research has found the chances of surviving a crash decrease markedly above certain speeds, depending on the type of crash. It should be noted that the road user, as well as the angle of impact of a collision are also factors that impact the severity of a crash.

Figure 2 provides a severity guidance sheet.

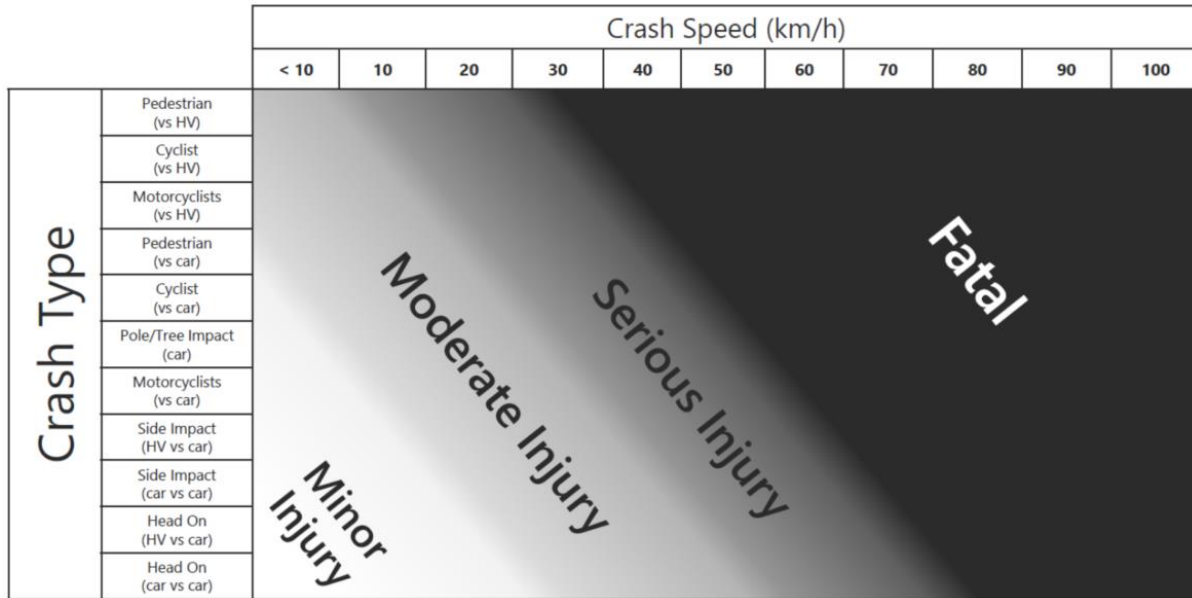

Figure 2: Severity guidance sheet

Appendix 2 – Likelihood / severity risk matrix

Figure 3 presents the likelihood / severity risk matrix.

			Severity*				
			Insignificant	Minor	Moderate	Serious	Fatal
			Property damage	Minor first aid	Major first aid and/or presents to hospital (not admitted)	Admitted to hospital	Death within 30 days of crash
Likelihood (Includes exposure)	Almost Certain	One per quarter	Medium	High	High	Extreme (FSI)	Extreme (FSI)
	Likely	Quarter to 1 year	Medium	Medium	High	Extreme (FSI)	Extreme (FSI)
	Possible	1 to 3 years	Low	Medium	High	High (FSI)	Extreme (FSI)
	Unlikely	3 to 7 years	Negligible	Low	Medium	High (FSI)	Extreme (FSI)
	Rare	7 years +	Negligible	Negligible	Low	Medium (FSI)	High (FSI)

*see Severity Guidance Sheet

Safe System crash outcome threshold

Figure 3: Likelihood / severity risk matrix (Source: Austroads Guide to Road Safety Part 6 – Road Safety Audit (2022))

Appendix E Drivers Code of Conduct

Drivers Code of Conduct

Safe Driving Policy for Construction of Airport Business Park Station

Objectives of the Drivers Code of conduct

- To minimise the impact of earthworks on the local and regional road network;
- To minimise conflict with other road users;
- To minimise road traffic noise; and
- To ensure truck drivers use specified heavy vehicles routes between the Site and the sub-regional road network.

Code of Conduct

The code of conduct requires that while driving any vehicle for work-related purposes.

Drivers are to be issued with a copy of the Drivers Code of Conduct, and must comply with all of the following:

- Demonstrate safe driving and road safety activities.
- Abide by traffic, road and environmental legislations.
- Follow site signage and instructions.
- Drivers must only enter and exit the site via the approved entry and exit points and travel routes.
- Drivers must not use Elizabeth Drive west of Badgerys Creek Road arriving or departing the site.
- Drivers must avoid entering the WSA site through the Badgerys Creek Road / Pitt Street roundabout whenever possible.

The below activities in any vehicles will be considered as a breach of conduct and will result in removal from site:

- Reckless or dangerous driving causing injury or death.
- Driving whilst disqualified or not correctly licensed.
- Drinking or being under the influence of drugs while driving
- Failing to stop after an incident.
- Loss of demerit points leading to suspension of licence.
- Any actions that warrant the suspension of a licence
- Exceeding the speed limit in place on any permanent or temporary roads.

Driver Responsibilities

All Drivers on site must:

- Be responsible and accountable for their actions when operating a company vehicle or driving for the purposes of work.
- Display the highest level of professional conduct when driving a vehicle at all times.
- Ensure they have a current driver licence for the class of vehicle they are driving, and this licence is to be carried at all times.

- Immediately notify their supervisor or manager if their drivers' licence has been suspended, cancelled, or has had limitations applied.
- Comply with all traffic and road legislation when driving.
- Assess hazards while driving.
- Undertake daily pre-start checks of oil, tyre pressures, radiator and battery levels of company vehicles they regularly use.
- Drive within the legal speed limits, including driving to the conditions.
- Not drive outside of the approved heavy vehicle routes. All drivers must obey weight, length and height restrictions imposed by the National Vehicle Regulator, and other Government agencies. Heavy Vehicles shall adhere to the selected routes.
- Heavy vehicle drivers must have completed the Sydney Metro Safe Heavy Vehicle Driver Introduction Programme or equivalent competency
- Be cognisant of the noise and emissions requirements imposed within the NSW/ Australian Road Rules. Works must be constructed with the aim of achieving the construction noise management levels detailed in the Construction Noise Guideline.
- Do not queue on public roads unless a prior approval has been sought.
- Be aware that at no time may a tracked plant be permitted or required on a paved road.
- Never drive under the influence of alcohol or drugs, including prescription and over the counter medication if they cause drowsiness – to do so will merit disciplinary measures.
- All drivers to report to their supervisor if they have been prescribed medication prior to the start of work.
- Wear a safety seat belt at all times when in the vehicle.
- Avoid distraction when driving – the driver will adjust car stereos/mirrors etc. before setting off or pull over safely to do so.
- Report ALL near-misses, crashes and scrapes to their manager,
- Report infringements to a manager at the earliest opportunity.
- Report vehicle defects to a manager prior to the next use of the vehicle.
- Follow the approved site access/egress routes only.
- Follow speed limits as imposed within the estate.
- Keep loads covered at all times.

The Site Team Responsibilities

The Contractor is responsible to take all steps necessary to ensure company vehicles are as safe as possible and will not require staff to drive under conditions that are unsafe.

This will be achieved by undertaking the following:

- Ensuring all vehicles are well maintained and that the equipment enhances driver, operator and passenger safety by way of:
 - Pre-commencement checks for all new plant arriving on-site and prior to undertaking any work.
 - Daily prestart inspections for all plant, vehicles and equipment currently on-site.
 - All construction plant must be fitted with a flashing light, fire extinguisher and reverse alarms (or squawkers).
 - Ensure all operators onsite have a current driver's licence of the appropriate class.
 - Ensure maintenance requirements are met and recorded.
- Identify driver training needs and arranging appropriate training or re-training. This may include providing the below:

- Operator VOC assessment as part of all inductions.
- Regular Toolbox discussions on safety features, managing fatigue, approved heavy routes, driver responsibility and drink-driving.
- Encouraging Safe Driving behaviour by:
 - Ensuring the subcontractor is informed if their staff become unlicensed.
 - Not covering or reimbursing staff speeding or other infringement notices
 - Ensuring Legal use of mobile phones in vehicles while driving only and that illegal use is not undertaken.
- Encouraging better fuel efficiency by:
 - Use of other transport modes or remote conferencing, whenever practical.
 - Providing training on, and circulating information about, travel planning and efficient driving habits.

Crash or incident Procedure

- Stop your vehicle as close to it as possible to the scene, making sure you are not hindering traffic. Ensure your own safety first, then help any injured people and seek assistance immediately if required.
- Ensure the following information is noted:
 - Details of the other vehicles and registration numbers (photos with time stamps)
 - Names and addresses of the other vehicle drivers.
 - Names and addresses of witnesses.
 - Insurers details
- Give the following information to the involved parties:
 - Name, address and company details
- If the damaged vehicle is not occupied, provide a note with your contact details for the owner to contact the company.
- Ensure that the police are contacted should the following circumstances occur:
 - If there is a disagreement over the cause of the crash.
 - If there are injuries.
 - If you damage property other than your own.
- As soon as reasonably practical, report all details gathered to your manager.

Environmental Procedures.

A range of measures shall be implemented to ensure the following;

- No dirt or debris from the construction vehicles is tracked on to the public road network.
- Reduce the impacts to sensitive receivers, including, where practicable, starting noisy equipment away from sensitive receivers and implementing respite periods.
- Watering of dusty activities will be undertaken, or activities temporarily halted and then resumed once weather conditions have improved.
- Containment measures for spillages will be provided at appropriate locations and in close proximity to staff car park areas, dangerous goods stores areas and main Project work areas.
- Keep an accurate record which includes the range of measures undertaken to reduce environmental impacts.